

Locktite Manual Reset Gas Shut-Off Valves

Series 200 LT

Eclipse 200 LT valves are manually opening valves that automatically shut off the gas supply to a combustion system when any interlocking limit switch opens. The valve handle cannot be reset until the condition causing the open switch is corrected and all limit switches are closed. Typical limit switches include air pressure, gas pressure, temperature limit, and flame monitoring contacts. In the event of a power failure, the valve immediately closes.

Series 200 LT valves include two visual indicators of “open” or “closed” position: a red “flag” visible in the plastic dome on top of the valve; and the reset handle position as indicated by cast markings on the operator case. These valves also include two SPDT micro-switches that can be used for auxiliary circuits. Two contacts are made when the valve opens, and two are made when the valve is closed.



LISTED 326R



CGA 3.9
CSA 6.5 / ANSI Z21.21



U.S. Patent No. 3,259,357
Canadian Patent No. 764,833

1.0 Materials of Construction

- 1.1 **Operator housing**—heat treated cast aluminum.
- 1.2 **Valve body**—cast aluminum or cast iron depending on model selected.
- 1.3 **Valve disc**—steel with Hycar synthetic rubber bonded to provide soft seating on valve port.
- 1.4 **Valve shaft**—stainless steel.
- 1.5 **Closing spring**—stainless steel.
- 1.6 **Main shaft gas seal**—plated steel with O-ring.
- 1.7 **Main housing and terminal strip**—tightly sealed using nitrile (UL listed) gaskets in order to assure a raintight enclosure.

2.0 Operating Parameters & Requirements

- 2.1 Install a manual shutoff valve upstream of the Locktite® to facilitate maintenance.
- 2.2 Before installing the valve, remove pipe scale and foreign matter that may have accumulated in the connecting pipes.
- 2.3 Ambient temperature at the location of the valve should not exceed 125° F.
- 2.4 Flow through the valve must be in the direction indicated by the arrow on the valve body.
- 2.5 Do not use the valve body to support piping.
- 2.6 “LT” valves are agency listed as follows:
 UL listed for air, natural gas, LP gas & hydrogen.
 FM approved for natural, LP & manufactured gases.
 CSA approved for natural, LP, mixed and manufactured gases.
 For wet or corrosive gases such as coke oven or digester gas, corrosion-resistant trim must be installed at Eclipse. Be sure your valve was ordered to suit your application.
- 2.7 See Figure 1 for allowable mounting positions.

Figure1–Operator Orientation & Mounting Positions

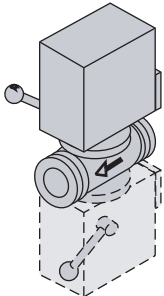
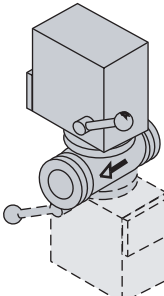
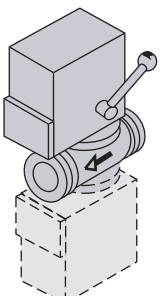
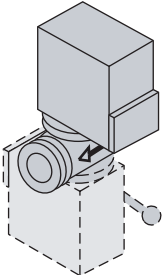
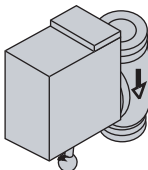
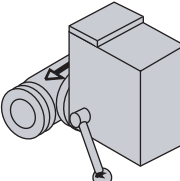
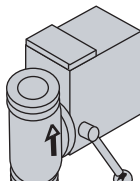
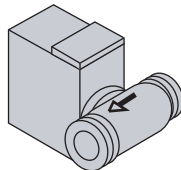
Factory Supplied Operator Position	#1 (Standard)	#2	#3	#4
Part Number Designation	Assembly No. (None)	Assembly No. -P2	Assembly No. -P3	Assembly No. -P4
Valve Mounted With Operator Straight Up or Down				
Valve Mounted With Wiring Box Cover Facing Up				

200 LT valves can be supplied with the operator rotated in any of four positions with respect to the valve body, #1, #2, #3, and #4. Position #1 is supplied standard. Add -P2, -P3, or -P4 to the end of the assembly number to specify other mounting positions. The sketches above show the allowable mounting orientations for each of the four factory-supplied operator positions. The operator must not be mounted in a position other than those shown.



Note: Field changing the operator position can result in damage. Please contact your Eclipse representative if rotation of the operator after shipment is required.

3.0 Pressure Taps & Position Indicators

- 3.1 The valve body has a plugged test connection upstream and downstream of the valve disc for leakage test and connection of pressure gauges.
- 3.2 An indicating “flag” enclosed in a clear plastic housing on top of the valve operator provides visual indication of the valve position. When the red indicating “flag” is visible, the valve is open; when it is not visible, the valve is closed.
- 3.3 The reset handle can also be used as a valve position indicator since it is spring loaded and automatically returns to the “reset” position when the valve closes.
- 3.4 The operator is equipped with two internal SPDT microswitches. These switches are normally used for actuating an alarm signal or for enforced low fire start of the system. The switch is rated for 8 amps, 1/3 HP, 120 or 240 volts A.C.

4.0 Wiring

- 4.1 Check valve nameplate to make certain electrical characteristics correspond with electrical service being used.
- 4.2 All wiring connections should be made in accordance with local or regional electric codes.
- 4.3 All internal wiring is connected at the factory to a terminal block included in the built-in wiring compartment of the valve (see figure 4). Make all field connections to this terminal block. Strip the wire 1/4" to 3/8". Insert into the terminal opening and tighten the screws. Check for loose strands that may cause a short.
- 4.4 Wiring diagrams for the latching solenoid and microswitch(es) are located on the inside surface of the terminal block cover, and also in Figure 4.
- 4.5 The operator has two 1/2" threaded conduit connections for field wiring. Use wiring suitable for 75° C operation.
- 4.6 For raintight applications, wiring connections to the valve must be made with 90° close ell rigid conduit fittings. The conduit should travel downwards from the valve to cause water to flow away from the valve.

Figure 4—Wiring Details

Terminal Block

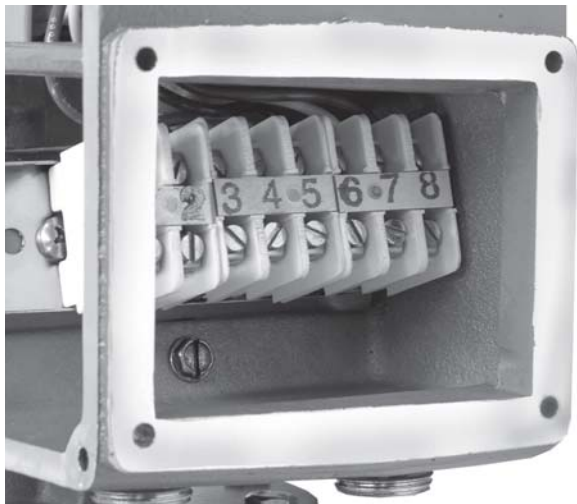

Wiring Diagram

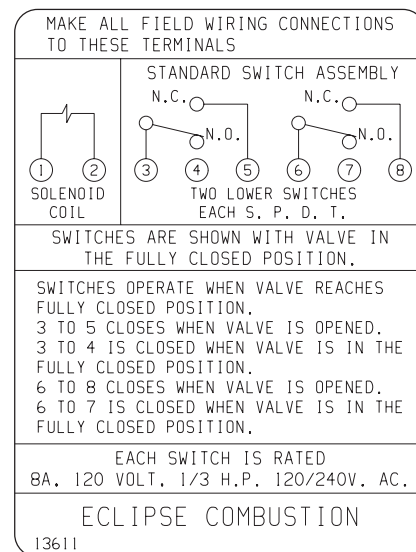

5.0 Maintenance

- 5.1 Every six months, lubricate the lever with light motor oil as shown to the right.
- 5.2 Since the "LT" valve is a safety device, test it regularly for proper functioning. Interrupt electrical power to simulate an unsafe condition. **If the valve does not close immediately, remove it from service and replace.**

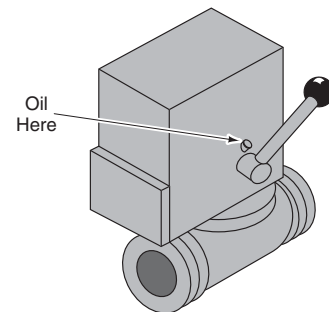

6.0 Replacement of Solenoid & Bracket Assembly (See Fig. 5 Page 4)

- 6.1 Remove main housing cover and gasket.
- 6.2 Remove the wiring box cover. Disconnect solenoid lead wires from the terminal block.
- 6.3 Remove the three 10-32 machine screws holding the cast solenoid bracket and microswitch bracket to the operator housing. Remove both brackets.
- 6.4 Mount the new solenoid and bracket assembly in the operator housing, replace the microswitch bracket, replace the three 10-32 screws, reconnect lead wires, and install main and side gaskets and covers.

Figure 5—View of Valve With Side Cover Removed

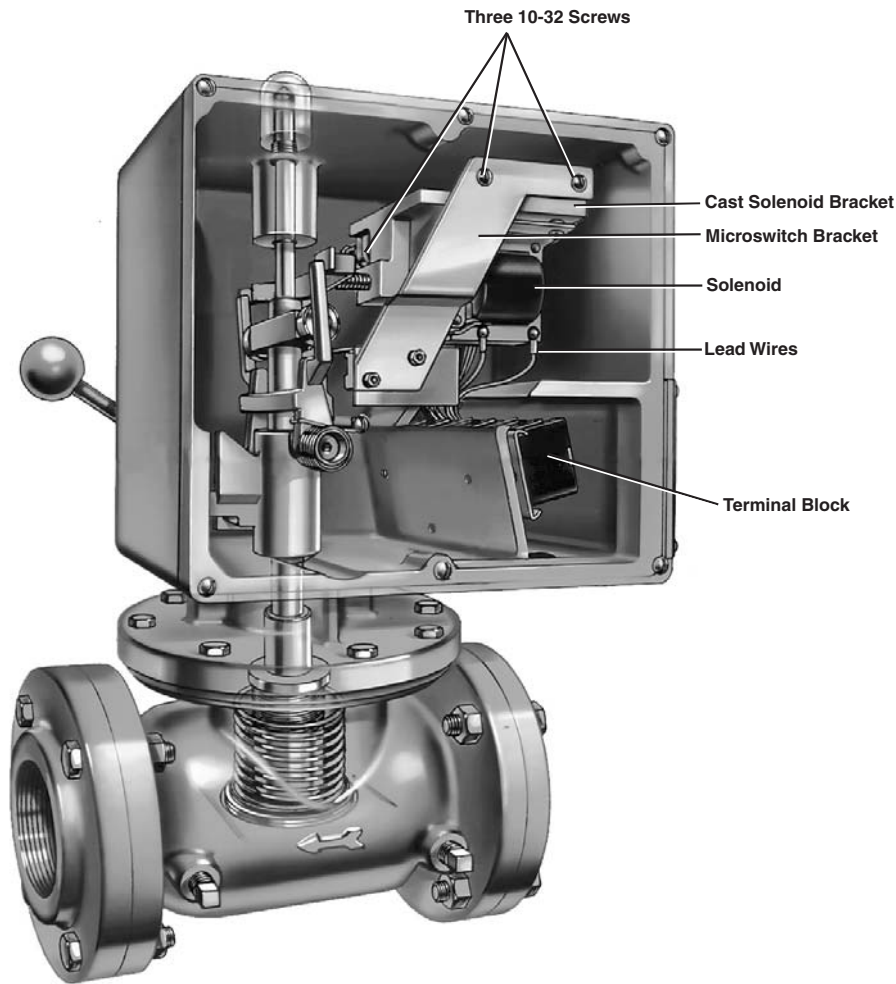

7.0 Changing The Mounting Position in The Field



Warning:

Service must be done by a competent technician with prior experience and knowledge of safety shut-off valves and safe maintenance procedures.

- 7.1 Turn off the gas supply to the valve and disconnect the field installation electrical wiring before working on the valve. Conduit may also need to be removed to allow proper orientation in the new mounting position.
- 7.2 If the valve is not mounted, clamp the body in a vise.
- 7.3 Connect a flexible temporary power source to terminals 1 and 2. Apply power and move the handle to the open position. Look at the visual indicator to verify that the valve is open. Do not remove power during the following steps.
- 7.4 Loosen and remove the 8 hex-head bolts holding the operator to the valve body.
- 7.5 Carefully lift the operator straight up until the stem clears the body.
- 7.6 Inspect the gasket for any problem that may lead to gas leakage. If any problem is detected, stop and contact Eclipse.
- 7.7 Rotate the operator to the desired position and carefully lower it straight into the valve body.
- 7.8 Replace and evenly tighten the 8 bolts to 50-60 lb-in (approximately $\frac{1}{2}$ turn after the hex-head is finger tightened to contact the surface).
- 7.9 Interrupt the power source and observe that the valve closes. Reapply power and verify that the valve opens properly.
- 7.10 Disconnect the temporary power source.
- 7.11 Restore the field connections and perform gas leakage tests before putting the system into service.