



Multi-Flame

Multiple Burner Monitoring System

Model 6000

Version 1.02

U.S. Patent No. 5,549,469

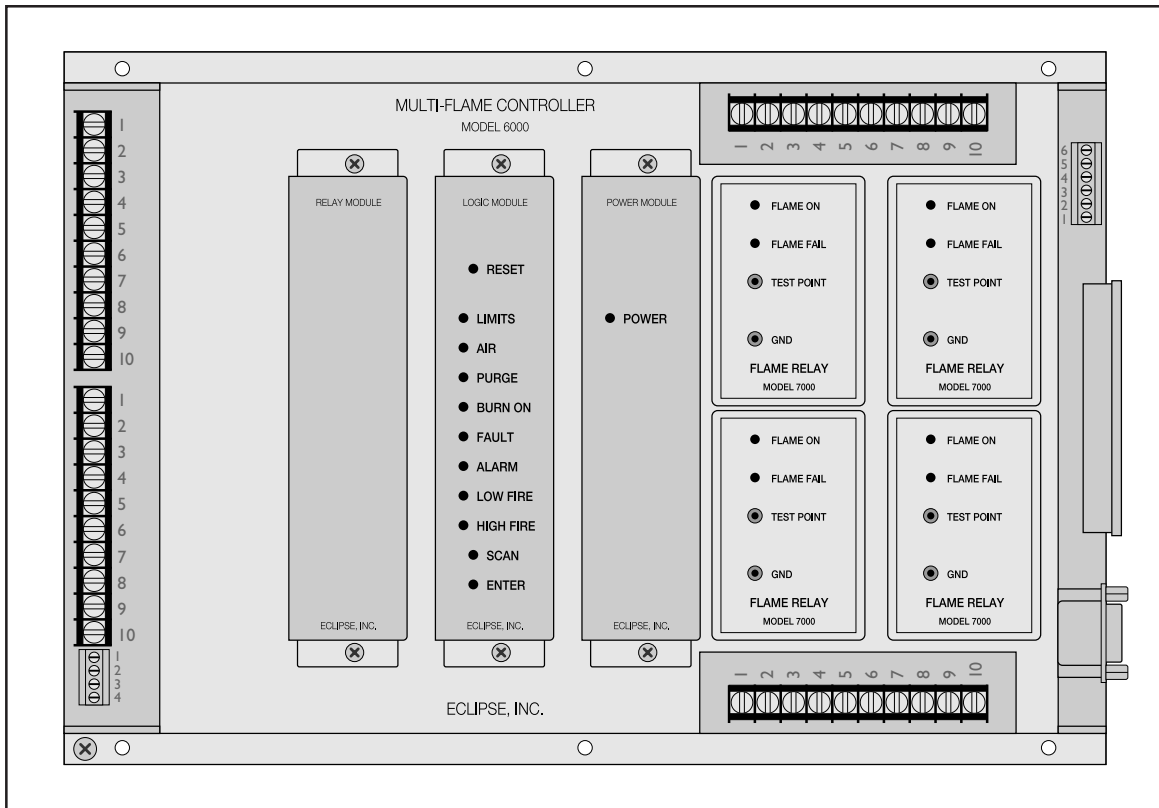

COPYRIGHT

Copyright 1996 by Eclipse Combustion. All rights reserved worldwide. This publication is protected by federal regulation and shall not be copied, distributed, transmitted, transcribed or translated into any human or computer language, in any form or by any means, to any third parties, without the express written consent of Eclipse Combustion.

DISCLAIMER NOTICE

In accordance with the manufacturer's policy of continual product improvement, the product presented in this brochure is subject to change without notice or obligation.

The material in this manual is believed adequate for the intended use of the product. If the product is used for purposes other than those specified herein, confirmation of validity and suitability must be obtained. Eclipse Combustion warrants that the product itself does not infringe upon any United States patents. No further warranty is expressed or implied.

We have made every effort to make this manual as accurate and complete as possible. Should you find errors or omissions, please bring them to our attention so that we may correct them. In this way we hope to improve our product documentation for the benefit of our customers. Please send your corrections and comments to our Marketing Communications Manager.

LIABILITY AND WARRANTY

It must be understood that Eclipse Combustion's liability for its products, whether due to breach of warranty, negligence, strict liability, or otherwise, is limited to the furnishing of burner monitoring system replacement parts and Eclipse Combustion will not be liable for any other injury, loss, damage or expenses, whether direct or consequential, including but not limited to loss of use, income of, or damage to material arising in connection with the sale, installation, use of, inability to use or the repair or replacement of Eclipse Combustion's products.

Eclipse Combustion, for a period of one year from shipment, warrants each Multi-Flame burner monitoring system to the original purchaser to be free from defects in material and workmanship under normal use as defined hereafter. Any operation expressly prohibited in this Guide, any adjustment or assembly procedures not recommended or authorized in these instructions, shall void the warranty.

About this manual

AUDIENCE

This manual has been written for the people who select and install the product and the technicians who work on it. They are expected to have previous experience with this kind of equipment.

IMPORTANT NOTICES

- Read this manual carefully. Make sure that you understand the structure and contents of this manual.
- Obey all the safety instructions.
- Do not deviate from any instructions or application limits in this manual without written consent from Eclipse Combustion.
- If you do not understand any part of the information in this manual, do not continue. Contact your Eclipse sales office or Eclipse Combustion.

DOCUMENT CONVENTIONS

There are several special symbols in this document. You must know their meaning and importance.

The explanation of these symbols follows. Please read it thoroughly.



Danger:

Indicates hazards or unsafe practices which **WILL** result in severe personal injury or even death. Only qualified and well trained personnel are allowed to carry out these instructions or procedures.

Act with great care and follow the instructions.



Warning:

Indicates hazards or unsafe practices which could result in severe personal injury or damage.

Act with great care and follow the instructions.



Caution:

Indicates hazards or unsafe practices which could result in damage to the machine or minor personal injury.

Act carefully.



Note:

Indicates an important part of the text.

Read the text thoroughly.



Table of Contents

	About this manual	<i>iii</i>
	Table of contents	<i>iv</i>
1	Introduction	<i>1-1</i>
	Product Description	<i>1-1</i>
2	Specifications	<i>2-1</i>
	Introduction	<i>2-1</i>
	Specifications	<i>2-1</i>
	Dimensions	<i>2-2</i>
3	Modules Description	<i>3-1</i>
	Introduction	<i>3-1</i>
	Module Description and Identification	<i>3-1</i>
	Relay Module	<i>3-1</i>
	Logic Module	<i>3-1</i>
	Power Module	<i>3-1</i>
	Peek-A-Flame	<i>3-2</i>
	Expansion Board	<i>3-2</i>
	Remote Display	<i>3-2</i>
4	DIP Switch Selection	<i>4-1</i>
	Introduction	<i>4-1</i>
	DIP Switch Location	<i>4-1</i>
	DIP Switch Access	<i>4-1</i>
	S2 DIP Switch Settings	<i>4-2</i>
	S4 DIP Switch Settings	<i>4-2</i>
	S6 DIP Switch Settings	<i>4-2</i>

5

Function Summary	5-1
Introduction	5-1
Standard Features	5-1
Combustion Air Flow Check Terminal	5-1
Main Fuel Valve Proof-of-Closure Terminal	5-1
Low Fire Start Terminal	5-1
High Fire/High Fire Purge Check Terminal	5-1
Recycle Mode	5-2
Pilot Test Mode	5-2
Interrupted or Intermittent Pilot	5-2
Spark, Pilot Flame & Main Flame Separation	5-2
System Faults	5-3
System Lockout Conditions	5-3
Optional Features	5-4
Auxiliary Inputs with History Log	5-4
History Log Activation	5-4
High to Low Fire Purge Modulation Capability with High to Low Fire Position Switch Interlocks	5-5
Valve Leak Sensing Device (VLSD) Interface	5-6
Remote Display Units	5-7
RS232/RS485 Communication Interfaces	5-7
Logic Module Status Lights & Push-buttons	5-8
Limits	5-8
Air	5-8
Purge	5-8
Burner On	5-8
Fault	5-8
Alarm	5-8
Low Fire	5-8
High Fire	5-9
Scan	5-9
Enter	5-9

6

System Installation	6-1
Introduction	6-1
Interlocks and Limit Switch Input	6-1
Combustion Air Switch Input	6-1
Ignition Wiring	6-2
Communication Wiring	6-2
Power Supply	6-2
Low Fire Input	6-2
Main Valve Proof-of-Closure	6-2
High Fire Input	6-2
Remote Reset	6-2
Expansion Boards	6-3
Remote Display	6-3
Terminal Strips Identification & Location (Figure 6.1)	6-4

6	Wiring Diagram & Connections—Main Chassis (Figure 6.2).....	6-5
	Wiring Diagram & Connections— Expansion Board for up to Four Burners (Figure 6.3)	6-6
	Wiring Diagram & Connections— Expansion Board for up to Eight Burners (Figure 6.3)	6-7
7	Sensor Installation	7-1
	Introduction	7-1
	Sensor Wiring	7-1
	Flame Rods	7-2
	Scanners	7-2
	Scanner Sighting Considerations	7-3
8	Test Procedures	8-1
	Introduction	8-1
	Flame Signal Strength	8-1
	Minimum Pilot Test	8-1
	Pilot Flame Failure Test	8-2
	Main Flame Failure Test	8-2
	Spark Sighting Test	8-2
	Limits & Interlock Tests	8-2
9	Maintenance & Troubleshooting	9-1
	Introduction	9-1
	Maintenance	9-1
	Monthly Checklist	9-1
	Yearly Checklist	9-2
	Troubleshooting	9-3
10	Remote Display Messages	10-1
	Introduction	10-1
	Multi-Flame Operating Sequence (Table 10.1)	10-2
	Remote Display Diagnostic Messages (Table 10.2)	10-6
	Appendix	A-1
	Conversion Factors	A-1
	Illustrated Parts List	A-2

Introduction

1

PRODUCT DESCRIPTION

The Eclipse Combustion Multi-Flame Burner Monitoring System controls the start-up sequence and monitors the flame of up to 20 individual gas, oil, or combination gas/oil burners connected to a common valve train. Its dynamic on-board testing checks for faulty relays, proof of valve closure, high and low fire switch interlocks, and shorted air switch.

The microcomputer based system features a plug-in modular design so any of the modules attached to the motherboard can be replaced by shutting down the Multi-Flame or the monitored burners. Its DIP switches allow sequence and timing functions, as well as system configuration. It is also capable of modulation (high and low fire purging) and monitoring up to four auxiliary inputs, history logging, and interfacing to valve leakage detection devices. It is UL recognized, FM approved and CSA certified.

Figure 1.1 Multi-Flame Burner Monitoring System

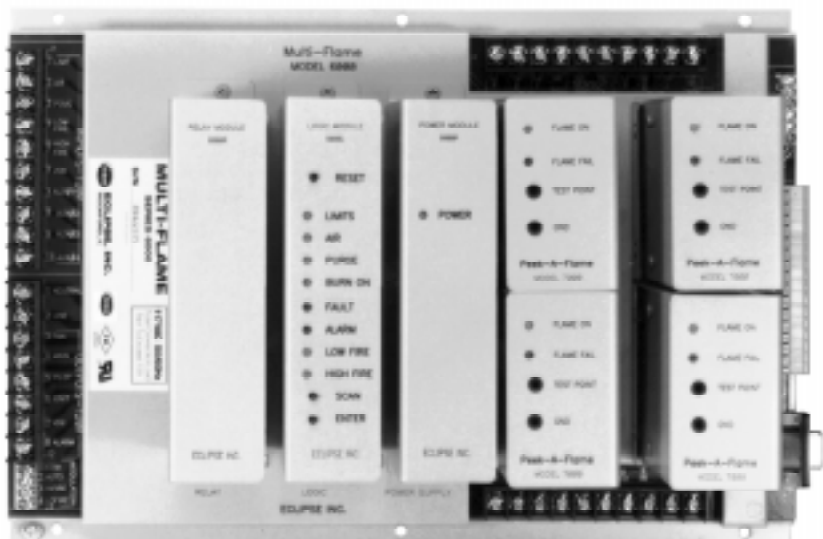



Specifications

2

INTRODUCTION

This section gives a detailed overview of Multi-Flame specifications and dimensions.

Specifications

PARAMETER	DESCRIPTION																					
Supply	<ul style="list-style-type: none"> 120 VAC (+10%, -15%), 50/60 Hz standard. 																					
Temperature Ranges	<table border="1"> <thead> <tr> <th>Unit</th> <th>Model Nos.</th> <th>Temperature Range</th> </tr> </thead> <tbody> <tr> <td>Multi-Flame</td> <td>6000</td> <td>-40° to +60°C (-40° to +140°F)</td> </tr> <tr> <td>Peek-A-Flame</td> <td>7000</td> <td>-40° to +60°C (-40° to +140°F)</td> </tr> <tr> <td>90° U.V. Scanner</td> <td>5600-90A</td> <td>-20° to +60°C (0° to 140°F)</td> </tr> <tr> <td>U.V. Scanner</td> <td>5600-91</td> <td>-40° to +125°C (-40° to +257°F)</td> </tr> <tr> <td>Self-Check U.V.</td> <td>5602-91</td> <td>-40° to +60°C (-40° to +140°F)</td> </tr> <tr> <td>Remote Display</td> <td>6000D</td> <td>0° to 50°C (32° to 122°F)</td> </tr> </tbody> </table>	Unit	Model Nos.	Temperature Range	Multi-Flame	6000	-40° to +60°C (-40° to +140°F)	Peek-A-Flame	7000	-40° to +60°C (-40° to +140°F)	90° U.V. Scanner	5600-90A	-20° to +60°C (0° to 140°F)	U.V. Scanner	5600-91	-40° to +125°C (-40° to +257°F)	Self-Check U.V.	5602-91	-40° to +60°C (-40° to +140°F)	Remote Display	6000D	0° to 50°C (32° to 122°F)
Unit	Model Nos.	Temperature Range																				
Multi-Flame	6000	-40° to +60°C (-40° to +140°F)																				
Peek-A-Flame	7000	-40° to +60°C (-40° to +140°F)																				
90° U.V. Scanner	5600-90A	-20° to +60°C (0° to 140°F)																				
U.V. Scanner	5600-91	-40° to +125°C (-40° to +257°F)																				
Self-Check U.V.	5602-91	-40° to +60°C (-40° to +140°F)																				
Remote Display	6000D	0° to 50°C (32° to 122°F)																				
Flame Failure Response	<ul style="list-style-type: none"> 3 seconds ±0.5 seconds. 																					
TFI/Pilot Interrupt	<ul style="list-style-type: none"> 5, 10 or 15 seconds selectable. 																					
Purge Time	<ul style="list-style-type: none"> <i>Modulating</i>: selectable from 0-225 seconds in 15 second increments. <i>Process</i>: selectable from 30 seconds to 13.5 minutes in 30 second increments. 																					
Contact Ratings @ 120 VAC (maximum total connected load not to exceed 15 amps)	<table border="1"> <thead> <tr> <th>Function</th> <th>Affected Terminals</th> <th>Inductive Load</th> <th>Resistive Load</th> </tr> </thead> <tbody> <tr> <td>Output Relay</td> <td>J2-4 through J2-8</td> <td>1/3 HP</td> <td>10 amps</td> </tr> <tr> <td>Output Relay</td> <td>J2-3</td> <td>1/2 HP</td> <td>15 amps</td> </tr> <tr> <td>Modulation</td> <td>J3-1 through J3-4</td> <td>1/3 HP</td> <td>10 amps</td> </tr> </tbody> </table>	Function	Affected Terminals	Inductive Load	Resistive Load	Output Relay	J2-4 through J2-8	1/3 HP	10 amps	Output Relay	J2-3	1/2 HP	15 amps	Modulation	J3-1 through J3-4	1/3 HP	10 amps					
Function	Affected Terminals	Inductive Load	Resistive Load																			
Output Relay	J2-4 through J2-8	1/3 HP	10 amps																			
Output Relay	J2-3	1/2 HP	15 amps																			
Modulation	J3-1 through J3-4	1/3 HP	10 amps																			
Approvals	<ul style="list-style-type: none"> UL Recognized (File – MH12613) FM Approved (File – J10Y3A5.AF) CSA Certified (File – LR37456) 																					
U.S. Patent	<ul style="list-style-type: none"> Number Issued: 5, 549, 469 Date Issued: August 27, 1996 																					
Shipping Weight	<ul style="list-style-type: none"> 7 kilograms (15 lbs.) for four burner unit. 																					

Dimensions

Main Chassis (For two to four burners)

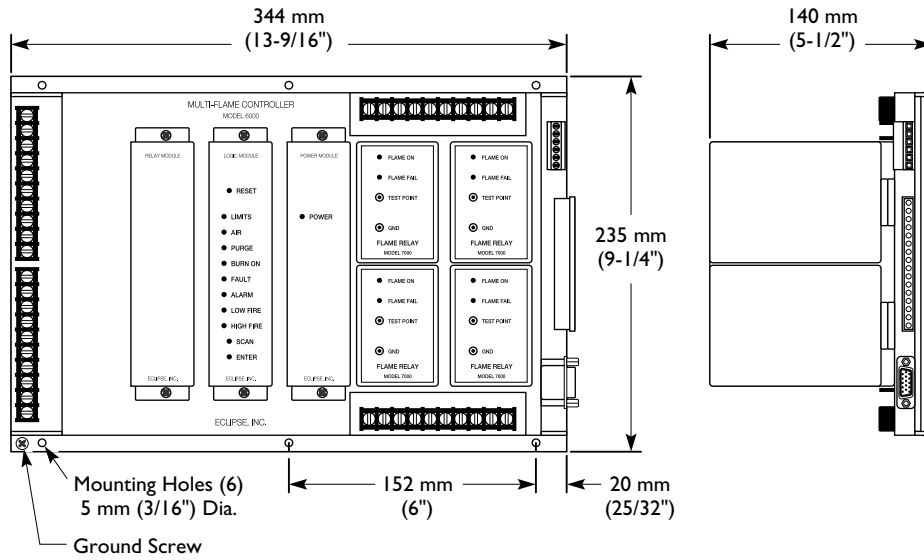

Expansion Boards

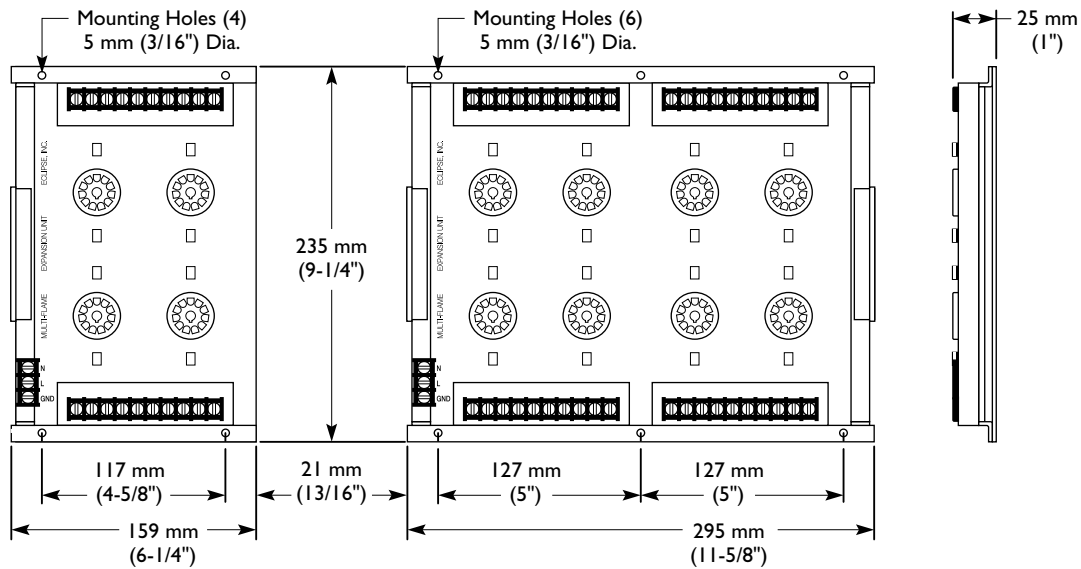

Remote Display (Shown with remote keypad and reset)

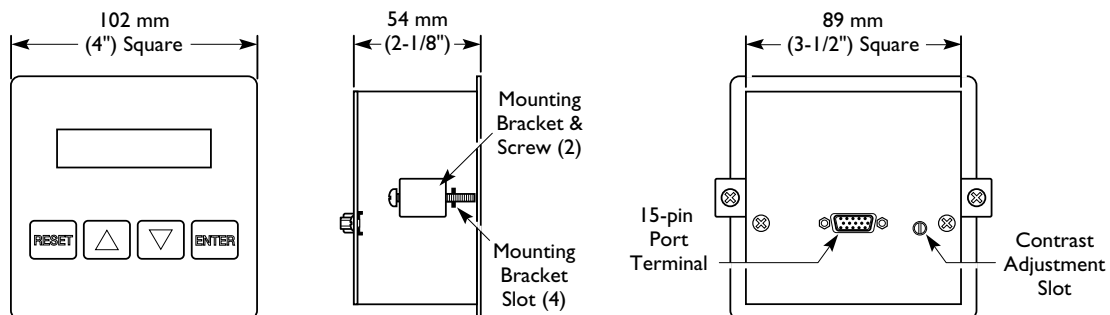

Modules Description

3

INTRODUCTION

In this section, you will find descriptions of the various modules which comprise the Multi-Flame multiple burner flame monitoring system, whether standard or optional items.

MODULE DESCRIPTION AND IDENTIFICATION

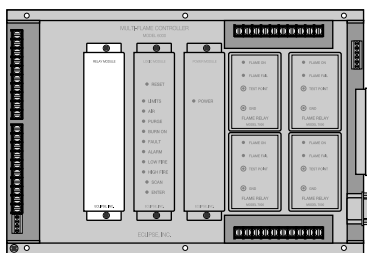

Relay Module location

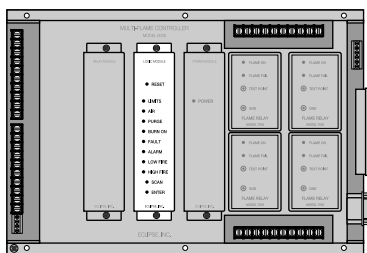

Logic Module location

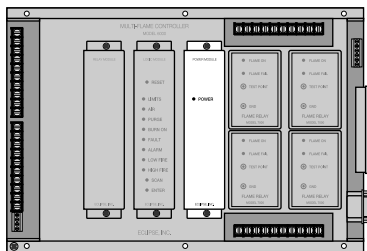

Power Module location

Relay Module

The relay module contains the output relays which provide power for operating the ignition coil, pilot valve, main valve, combustion fan and alarm. This module is mounted in the first position on the left of the motherboard closest to the output terminals.

Logic Module

The logic module houses the microcomputer which provides all the sequential logic and safety start-up and shutdown circuitry. On the front of this module is the reset, scan and enter push-buttons, and status lights. This module is mounted in the second position from the left of the motherboard next to the relay module.

Power Module

The power module supplies the power required for the electronic circuitry. It is mounted in the motherboard to the right of the logic module. The green LED on the front indicates that power is on to the Multi-Flame.

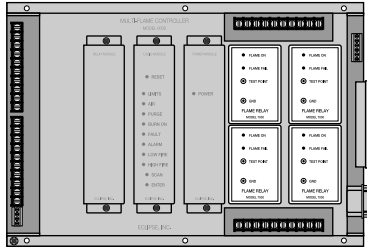

Peek-A-Flame locations

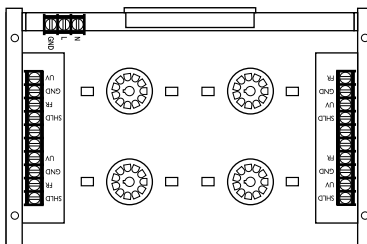
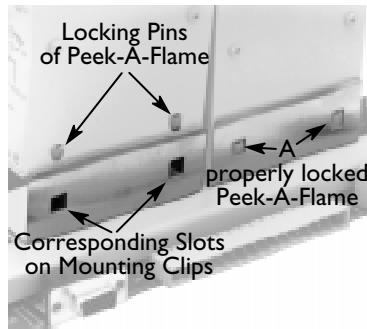

Expansion Board
(for four additional burners)

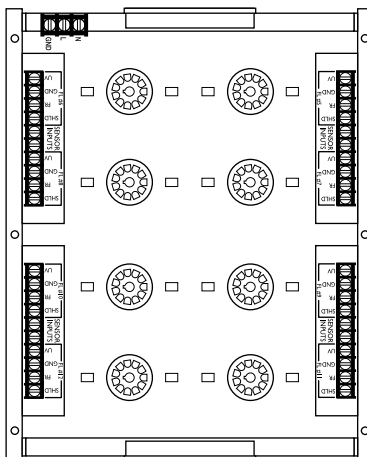

Expansion Board
(for eight additional burners)

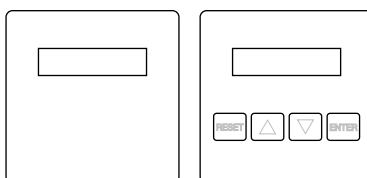

Remote Displays

Peek-A-Flame Module

The Eclipse Peek-A-Flame is the flame sensing module of the Multi-Flame. One Peek-A-Flame is required for each burner in the system.

The Peek-A-Flames are installed into the motherboard by carefully inserting them into the round 11-pin sockets. Each Peek-A-Flame is held in place by means of a mounting clip, as shown at left. On the front of the Peek-A-Flame module is a “Flame On” LED, which illuminates when a flame is detected at the corresponding burner and flashes once per second on flame failure. Directly below the “Flame ON” LED is a “Flame Fail” LED, which also flashes once per second on flame failure.

The Peek-A-Flame incorporates test point and ground (GND) connection jacks in the front of the unit. Using these, the flame signal strength of each burner can be measured using a 0-15 VDC, one megohm/volt meter as explained and shown in “Flame Signal Strength” on page 8-1.

Expansion Board

The expansion board contains the mounting sockets and connection terminals for adding additional Peek-A-Flame units, which is needed for systems having more than four burners. There are two expansion boards available: one for adding up to four more burners and one for adding up to eight more burners. For systems monitoring 13 to 20 burners, two of the expansion boards for up to eight more burners are used.

A cable connects either expansion board to the motherboard (J8 on the motherboard to J2 on the expansion board), as well as two expansion boards together (J7 on one expansion board to J2 on the other expansion board); see Figure 6.1 on page 6-4 for terminal strips identification and location.



Note:

The four burner expansion board CANNOT be used in conjunction with the eight burner expansion board.

Remote Display

The remote display provides alphanumeric messages which indicate burner status as well as annunciate lockout condition in the Multi-Flame system. There are two remote displays available: one which provides alphanumeric messages only, and one which also provides remote reset, a keypad and history logging capability.

A cable connects the remote display to the motherboard; this cable is available in six and 10 feet lengths.



DIP Switch Selection

4

INTRODUCTION

This section details the location, selection and description of the Multi-Flame DIP switches, which allow for sequence and timing functions as well as system configuration.



Caution:

To avoid electric shock, shut off the power supply when installing any control device. Flame monitoring systems must be installed by a qualified, licensed technician.

DIP SWITCH LOCATION

All of the DIP switches are located in the logic module, which is mounted in the second position from the left of the motherboard next to the relay module (see page 3-1 for logic module location).

DIP SWITCH ACCESS

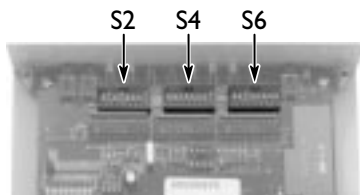

To gain access to the DIP switches, the cover of the logic module must be removed. To do this, remove the two screws which hold the logic module to the motherboard. Then gently pull the logic module towards you to disengage the terminal pins at the module base. On one side of the module is a description of the DIP switch functions; the opposite side has four small screws which hold the logic module cover to the base. Remove these four screws to expose the logic board. The photo to the left shows the DIP switch locations.

DIP SWITCH SETTINGS

8	120 SEC.	MODULATION	30 SEC.	PROCESS
7	60 SEC.	PURGE TIME (ADDITIVE)	7 MIN.	PURGE TIME (ADDITIVE)
6	30 SEC.	S4/SW8 = ON	3 MIN.	S4/SW8 = OFF
5	15 SEC.		2 MIN.	
4			1 MIN.	
3	10 SEC. TFI = ON 5 SEC. TFI = OFF (S4/SW7 = ON)		10 SEC. TFI = ON 15 SEC. TFI = OFF (S4/SW7 = OFF)	
2	INTERMITTENT PILOT		INTERRUPTED PILOT	
1	RECYCLING		NON-RECYCLING	
ON ↔ OFF				

S2 DIP Switch Settings Example

If the TFI needed is:	THEN SW3 of S2 DIP switch must be turned:	AND SW7 of S4 DIP Switch must be turned:
5 seconds	Off	On
10 seconds	On	On
15 seconds	On	Off

Trial-for-Ignition (TFI) Settings

S2 DIP Switches

The S2 DIP switches permit programming of timing and sequence functions of the Multi-Flame.



Note:

The S2 DIP switch settings at left are for illustrative purposes only; the actual settings of any of these switches will be determined by your system conditions.

SW1: Recycling mode selection (On=Recycling; Off=Non-recycling)

SW2: Pilot selection (On=Intermittent, where pilot remains on during burner cycle; Off=Interrupted, where pilot valve closes after main burner is established).

SW3: Trial-for-ignition (TFI) range selection; see the table at left for proper selection.

SW4 through 8: Purge time selection (switch settings are additive); see illustration at left for exact times.

S4 DIP Switches

Only SW7 of the S4 DIP switches is used; along with SW3 of the S2 DIP switches, it affects trial-for-ignition (TFI) range selection. See the table at left for proper selection.

S6 DIP Switches

The S6 DIP switches permit selection of the number of burners in the system as follows:

No. of Burners	SW1	SW2	SW3	SW4	SW5	SW6 thru 8
1	On	Off	Off	Off	Off	Off
2	Off	On	Off	Off	Off	Off
3	On	On	Off	Off	Off	Off
4	Off	Off	On	Off	Off	Off
5	On	Off	On	Off	Off	Off
6	Off	On	On	Off	Off	Off
7	On	On	On	Off	Off	Off
8	Off	Off	Off	On	Off	Off
9	On	Off	Off	On	Off	Off
10	Off	On	Off	On	Off	Off
11	On	On	Off	On	Off	Off
12	Off	Off	On	On	Off	Off
13	On	Off	On	On	Off	Off
14	Off	On	On	On	Off	Off
15	On	On	On	On	Off	Off
16	Off	Off	Off	Off	On	Off
17	On	Off	Off	Off	Off	On
18	Off	On	Off	Off	Off	On
19	On	On	Off	Off	Off	On
20	Off	Off	On	Off	Off	Off



Function Summary

5

INTRODUCTION

This section describes the function features of the Multi-Flame that can be found on the various terminal strips and the modules of the Multi-Flame. It is broken into three categories: Standard features, Optional features and the LED Indicator Lights of the logic module.

STANDARD FEATURES

The following function features are standard on the Multi-Flame:

Combustion Air Flow Check Terminal

The Multi-Flame checks that the combustion air flow switch is open before start-up, closed during operation and open again at burner shutdown, thus preventing operation with an air switch that is defective, maladjusted or jumpered.

Main Fuel Valve Proof-of-Closure Terminal

The Multi-Flame checks that the main fuel valve is closed before start-up and after burner shutdown. This arrangement requires an approved proof-of-closure switch on the main fuel valve.

Low Fire Start Terminal

When selected, the system checks for the low fire start position prior to light-off.

High Fire/High Fire Purge Check Terminal

When selected, the system checks that the air modulation motor reached the high fire position during high fire purge. The modulation motor must be fitted with a high fire position switch, which is then connected to the high fire check terminal. An air flow or pressure switch that is set to prove sufficient purge air may be used instead of the high fire position switch.

Recycle Mode

When selected, the Multi-Flame will restart the sequence after flame or air failure. The recycle mode allows the system to re-initiate the start-up sequence automatically, once the main burners have been operating for at least 35 seconds. If the pilot flame fails to light during recycling, the system will lock out and annunciate a pilot flame fail. If the recycle is successful and the main burners are operational for at least 35 seconds, the system is ready for another recycle. At no time will the system recycle in the event of pilot flame fail.

Pilot Test Mode

This mode is entered by depressing the “Reset” and the “Enter” buttons simultaneously then releasing the “Reset” button but holding the “Enter” button for another 10 seconds. The limits light will flash off and on, indicating that the system is in the test mode.

In the pilot test mode, the Multi-Flame operates normally with the exception that the main valves are not energized, preventing the main burners from igniting.

To exit the pilot test mode, simply press the “Reset” button and the Multi-Flame will exit the pilot test mode and restart the sequence.

Interrupted or Intermittent Pilot

Pilot mode is selected using the DIP switch (see “S2 DIP Switch Settings” on page 4-2). An interrupted pilot shuts off after the main flame is established. An intermittent pilot continues during the entire main flame firing cycle.

Spark, Pilot Flame and Main Flame Separation

During the trial for ignition period (TFI), the pilot valve and ignition coil remains energized. At the end of the TFI, the pilot flame remains on and the ignition coil is de-energized. After a five second delay to prove the pilot flame, the main gas valve is energized.



Note:

All pilots must light within the specified TFI or a pilot flame failure will occur. If one burner experiences either a pilot or main flame failure, then all burners will shut down. The failed burner will be indicated by the red flashing “Flame Fail” light on the corresponding Peek-A-Flame.

System Faults

A system fault (illuminated by the fault LED on the logic cards) prevents gas ignition but does not lock out the system. System fault conditions are as follows:

- 1) If a flame is detected out of sequence, which may be caused by:
 - a) a faulty scanner
 - b) electrical interference on the sensor leads
 - c) a flame exists in the burner due to a gas leak or other condition.
- 2) Air flow switch closed before start-up.

System Lockout Conditions

A system lockout will occur (illuminated by the alarm LED on the logic card) for any of the following conditions:

- 1) Air failure—loss of combustion anytime during the operational cycle.
- 2) Pilot flame fail—loss of flame during the trial for pilot ignition period.
- 3) Main flame fail—loss of flame during the main burner trial for ignition.
- 4) Main fuel valve—open after cycle shutdown or before start-up with interlocks closed.
- 5) Unmatched burners—the number of Peek-A-Flames installed does not match the number selected on the DIP switches (see “S6 DIP Switch Settings” on page 4-2).
- 6) Relay fail—failure of Multi-Flame internal relays.
- 7) Low fire fail—low fire switch open prior to trial for ignition.
- 8) High fire fail—high fire switch is not closed at the end of high fire purge.
- 9) Flame fail—loss of flame after main flame has been established.
- 10) If no purge time is set (see “S2 DIP Switch Settings” on page 4-2).
- 11) Wiring error which puts external voltage on any of the output terminals.
- 12) Welded internal contacts or other malfunctions in the Multi-Flame.

OPTIONAL FEATURES

The following features are available only on select models, and when the appropriate switches are selected on DIP switch S4:

Auxiliary Inputs with History Log

This feature provides four auxiliary inputs which are monitored by the Multi-Flame as alarm interlocks. This means that when the input voltage is interrupted, the system locks out and will annunciate on the optional remote display unit.

Once activated, a voltage of 120 VAC must be present at the input for the Multi-Flame system to operate. If an auxiliary input loses its voltage for more than one second while the interlocks and limits input is powered, then a lockout condition will occur. If the Multi-Flame is equipped with an optional remote display unit, then the following message will occur:

<u>Aux. Input #1</u>	<u>Aux. Input #2</u>	<u>Aux. Input #3</u>	<u>Aux. Input #4</u>
AUX.LIM.#1 FAIL	AUX.LIM.#2 FAIL	AUX.LIM.#3 FAIL	AUX.LIM.#4 FAIL
HH:MM:SS LOCKOUT	HH:MM:SS LOCKOUT	HH:MM:SS LOCKOUT	HH:MM:SS LOCKOUT



Note:

Unused auxiliary inputs should be connected to 120 VAC.

History Log Activation

The history log is only accessible through an optional remote display unit with remote reset, and when the Multi-Flame is in a “LOCKOUT” or “LIMITS OPEN” condition. The history log records the total number of operating cycles, and the last lockout messages up to a maximum of 10.

With a remote display available and the Multi-Flame in one of the two conditions described above, the history log can be accessed as follows:

- 1) Press and hold the ENTER key on the remote display unit until the following message appears:

**TOTAL OPERATING
CYCLES = XXXXX** (where X is a digit between 1 and 9).

The record number will display as long as the ENTER key is pressed.

- 2) Release and press the ENTER key a second time. The record number of the lockout message will be displayed:

RECORD #X (where X is the number of the most recent lockout)

(continued onto next page)

History Log Activation *(continued)*

- 3) Release the ENTER key and the most recent lockout message will display for seven seconds.
- 4) If you wish to see the next lockout message, press and release the ENTER key before the seven second time duration ends of the most recent lockout message display. This will prompt the next lockout message. If desired, continue this procedure until the maximum of ten lockout messages has been displayed (remember that the highest record number is the most recent lockout message).
- 5) Continued pressing and releasing of the ENTER key in less than seven seconds keeps the history log active and repeats the lockout message list; waiting longer than seven seconds deactivates the history log mode and the next display is the last sequence message before the history log was activated. For example, if the message "LIMITS OPEN" was displayed when the history log was activated, then that message will appear again after seven seconds.
- 6) If you wish to erase all of the lockout messages from the history log, press the RESET and ENTER keys simultaneously while the history log is active. Release the RESET key, but hold the ENTER key for another five seconds.

High to Low Fire Purge Modulation Capability with High to Low Fire Position Switch Interlocks

The modulation feature incorporates a high fire purge time and a low fire purge time into the purge sequence. This feature allows the Multi-Flame to sequence internal dry contacts which can be used by the customer requiring a high fire purge of the combustion chamber before ignition.

The high fire and low fire purge times are selectable by means of S2 DIP switches on the logic board (see "S2 DIP Switch Settings" on page 4-2):

S2 SW4	15 seconds	S2 SW7	120 seconds
S2 SW5	30 seconds	S2 SW8	0 seconds
S2 SW6	60 seconds		

The selected times are additive and apply to both the high fire and low fire purge times (that is, high and low fire times are always identical).

(continued onto next page)

High to Low Fire Purge Modulation Capability with High to Low Fire Position Switch Interlocks *(continued)*

With this option, the modulation terminals on J3 terminal strip will sequence as follows:

<u>Sequence Step</u>	<u>Internal Contact Connections</u>
High Fire Purge	Terminal 1 (COMMON) to Terminal 3 (HI FIRE)
Low Fire Purge	Terminal 1 (COMMON) to Terminal 4 (LOW FIRE)
Automatic	Terminal 1 (COMMON) to Terminal 2 (AUTO)
Power Off	Terminal 1 (COMMON) to Terminal 2 (AUTO)
Power On/Limits Off	Terminal 1 (COMMON) to Terminal 4 (LOW FIRE)
Alarm	Terminal 1 (COMMON) to Terminal 4 (LOW FIRE)

The Automatic step occurs when the burners are operating (see Table 10.1 on page 10-4) and allows the burner firing rate to be controlled by an automatic temperature controller.

Valve Leak Sensing Device (VLSD) Interface

The Multi-Flame Valve Leak Sensing Device (VLSD) interface is currently designed for use with an Eclipse-Dungs VDK by providing a 120 VAC output which triggers the start of the test period. An input is also provided which receives a 120 VAC signal from the VDK. If the signal is received within the test period (40 seconds), then the test has been successfully completed. This option includes the required sequential software to initiate the valve leak test on start-up and shutdown of the burners.

When the limits close to the Multi-Flame, the 120 VAC output to the VLSD is activated. If an optional remote display is connected, the following message will appear:

VALVE LEAKAGE

UNDERTEST XX (*where X is the remaining seconds of the test*).

If the VLSD does not activate the VLSD 120 VAC input within 40 seconds, then an alarm lockout will occur, and the following message will appear on the optional remote display:

VALVE LEAK FAIL

HH:MM:SS LOCKOUT

If a valve leak occurs, then the fan output on the Multi-Flame will be activated to purge the combustion chamber of gases.



Note:

If the VLSD input is not used, then it should be connected to 120 VAC.

Remote Display Units

There are two remote displays available: one with a keypad and one without a keypad. The remote with a keypad allows remote reset and activation of the history log option. Both units are panel mountable and feature a liquid crystal display in a 1/4 DIN housing. Either unit connects to the Multi-Flame by a six or 10 foot cable. The display incorporates the following features:

- 1) Provides status messages for the Multi-Flame sequence.
- 2) Indicates lockout conditions when they occur, as well as the amount of time into the sequence when the lockout occurred.
- 3) Provides continuous monitoring of each burner's flame signal strength during main burner operation. (Pressing ENTER once will lock on a particular burner's status; pressing ENTER a second time will resume scrolling).
- 4) Incorporates a remote reset key into front membrane of unit (remote with keypad only).
- 5) Provides the interface required for the History Log option (remote with keypad only).
- 6) Incorporates ENTER key for pilot test mode.

RS232/RS485 Communication Interfaces

Terminals 5 and 6 on Multi-Flame terminal strip J7 provide a serial output communication interface for remotely monitoring the system sequence and status using a terminal or a modem; refer to Section 10 for the types of messages sent by the Multi-Flame.

The communications protocol is 8 bit, no parity, 1 stop bit and 1200 baud. This feature is provided standard as a RS232 interface. The RS485 interface is optional.

Sending a carriage return (<CR> = ASCII Hex 0D) from the terminal causes the Multi-Flame to retransmit the last message. Sending a CTRL-E (<ENQ> = ASCII Hex 05) accesses the optional history log.

LOGIC MODULE STATUS LIGHTS & PUSH-BUTTONS

The logic module provides all the sequential logic, and safety start-up and shutdown circuitry. On the front of the module is the reset, scan and enter push-buttons, and status lights. This section describes their respective functions.

Limits

This LED illuminates when the operation limits are made. These limits are wired in series to terminal J1-1. This input becomes energized to begin the burner sequence. When in the test mode, this LED flashes (see “Pilot Test Mode” on page 5-2).

Air

This LED illuminates when the air switch is closed and power is thereby applied to the air switch input. The Multi-Flame also checks this input for an air switch short (see “Combustion Air Flow Check Terminal” on page 5-1).

Purge

This LED illuminates whenever the combustion blower is energized, including the purge period and the main burner period of the sequence. It blinks on and off while the purge is in process and remains constant when the purge process is complete.

Burner On

This LED illuminates when the main gas valve is energized, permitting gas flow to all the burners.

Fault

This LED illuminates when a system fault is detected and during the initial safe start check (see “System Faults” on page 5-3).

Alarm

This LED illuminates when an alarm condition causes a system lockout (see “System Lockout Conditions” on page 5-3).

Low Fire

This LED illuminates during the low fire period of the purge cycle.

High Fire

This LED illuminates during the high fire period of the purge cycle.

Scan

This push-button is for future use.

Enter

This push-button is used with the optional history logging.



System Installation

6

INTRODUCTION

In this section, the necessary procedures are detailed to integrate a Multi-Flame into a burner system; Figure 6.1 illustrates the various terminal strips mentioned.



Note:

Shut off the power supply before any module is removed or replaced from the unit, including the remote display.



Caution:

Installation and maintenance must conform with the National Electrical Code and all other national and local codes and authorities having jurisdiction.

INTERLOCKS AND LIMIT SWITCH INPUT

Interlocks are generally pressure or temperature switches which, when activated, start the burner. Limit switches are generally pressure, temperature and other switches which, when activated, stop the burner. The interlocks and limit switches are wired in series. A break in this circuit will shut the burner down, but will not produce an alarm. This input is considered the normal operation control input to the Multi-Flame system.

COMBUSTION AIR SWITCH INPUT

This input is for monitoring the combustion air switch separately from other interlocks and limits. When wired to this input, the air switch will be proven open before start-up and after shutdown. It will also be proven closed 10 seconds after the combustion air blower is energized.

If the air switch opens during the main firing cycle, the system will either lockout or recycle, depending on the DIP switch selection.

If this terminal is not used, place a jumper between the combustion blower output (terminal 3 on terminal strip J2) and the air switch input (terminal 2 on terminal strip J1).

If the combustion air blower is controlled outside of the Multi-Flame system, then the air switch must be wired between the combustion blower output and the air switch input. Connecting the air switch in this manner will prevent the open contact (air short) check on the switch.

IGNITION WIRING

Route ignition wiring a sufficient distance from all sensors and other low voltage wiring to avoid electrical interference, which may cause erratic operation of the Multi-Flame system. **Do not connect multiple ignition coils in excess of output relay contact rating.**

COMMUNICATION WIRING

Route communication wiring a sufficient distance from ignition and other high voltage wiring to avoid electrical interference.

POWER SUPPLY

All input power must be single phase 120 VAC, 60 Hz. All circuits must have a common 15 amp fuse and disconnect. The neutral must be grounded. **Do not use solid-state triac output devices in any of the input circuits.** 120 VAC wiring must be at least 90°C 16 AWG minimum and satisfy all applicable codes.

LOW FIRE INPUT

It is possible to wire the system for checking low fire start position prior to pilot ignition. To use this feature, the low fire start switch must be connected to the low fire start input (terminal 4 on terminal strip J1). If this feature is not used, a jumper must be placed between terminals 1 and 4 on terminal strip J1.

MAIN VALVE PROOF-OF-CLOSURE

The system can be wired to check for the proof of valve closure (POVC) switch on the main gas valve prior to start-up and after the end of the burner cycle.

To use this feature the POVC switch must be connected to the POVC switch input (terminal 3 on terminal strip J1). If this feature is not used, a jumper must be placed between terminals 2 on terminal strip J2 and 3 on terminal strip J1.

HIGH FIRE INPUT

The system can be wired to check for high fire position during the high fire purge portion of the sequence. To use this feature, the high fire position switch must be connected to the high fire input (terminal 5 on terminal strip J1). If this feature is not used, a jumper must be placed between terminals 1 and 5 on terminal strip J1.

REMOTE RESET

This feature permits remote mounting of a switch to reset the Multi-Flame. To use this feature, a normally closed remote reset switch must be wired between terminals 1 and 4 on terminal strip J7. When it is depressed or actuated, the connection between the aforementioned terminals is momentarily interrupted and resets the Multi-Flame. If neither remote reset nor remote LCD display is used, a jumper must be placed between terminals 1 and 4 on terminal strip J7. This is a low voltage signal circuit that must be routed separately from other control voltage wiring. Use two-conductor shielded cable with the shield connected on one end only to terminal 1 of J7.

EXPANSION BOARDS

There are two different expansion boards available: one for up to four additional burners and one for up to eight additional burners. Either expansion board is mounted on the sub-panel separate from the Multi-Flame motherboard. It requires its own power (120 VAC/ 60 Hz) connected to L, N, GND on terminal strip J1 (120 VAC to L, neutral to N and GND to ground).



Note:

The four burner expansion board CANNOT be used in conjunction with the eight burner expansion board.

The connection to the motherboard is made via a cable which joins two plug connectors at J8 on the motherboard and J2 on the expansion board. The connections between the two plugs are to matching numbers (i.e., pin 1 on J8 connected to pin 1 on J2).

The same two-plug connector cable is used in systems for 13 to 20 burners where two expansion boards are linked to the motherboard. The first expansion board is connected to the motherboard as described above, while J2 of the second expansion board is connected to J7 of the first expansion board.

Sensor connections are made for the corresponding Peek-A-Flame at terminals J3 and J4.

REMOTE DISPLAY

When installed, the remote display must be grounded. Panel mounting is through a 1/4 DIN cutout (see page 2-2). Use either the 6 or 10 foot cable to connect it to the motherboard.

Figure 6.1 Terminal Strips Identification & Location

Main Chassis (For two to four burners)

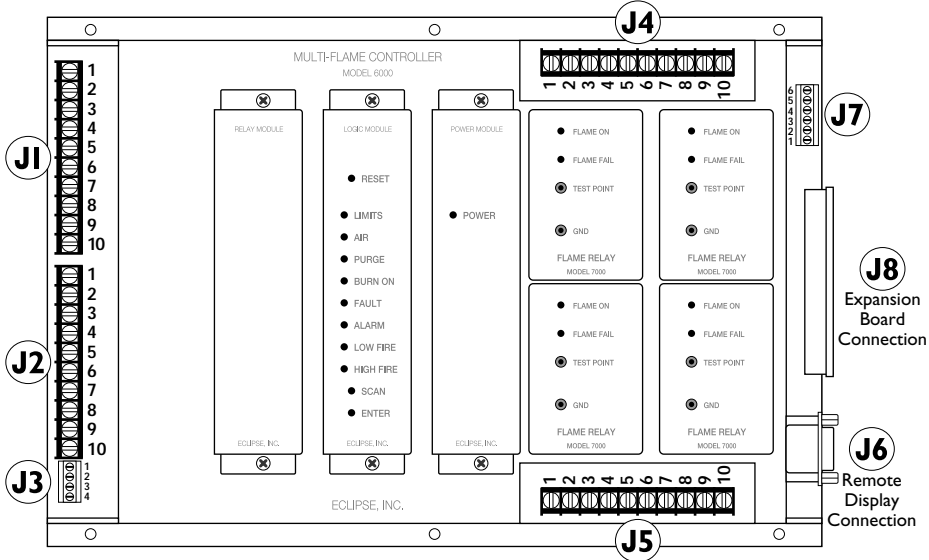

Expansion Boards

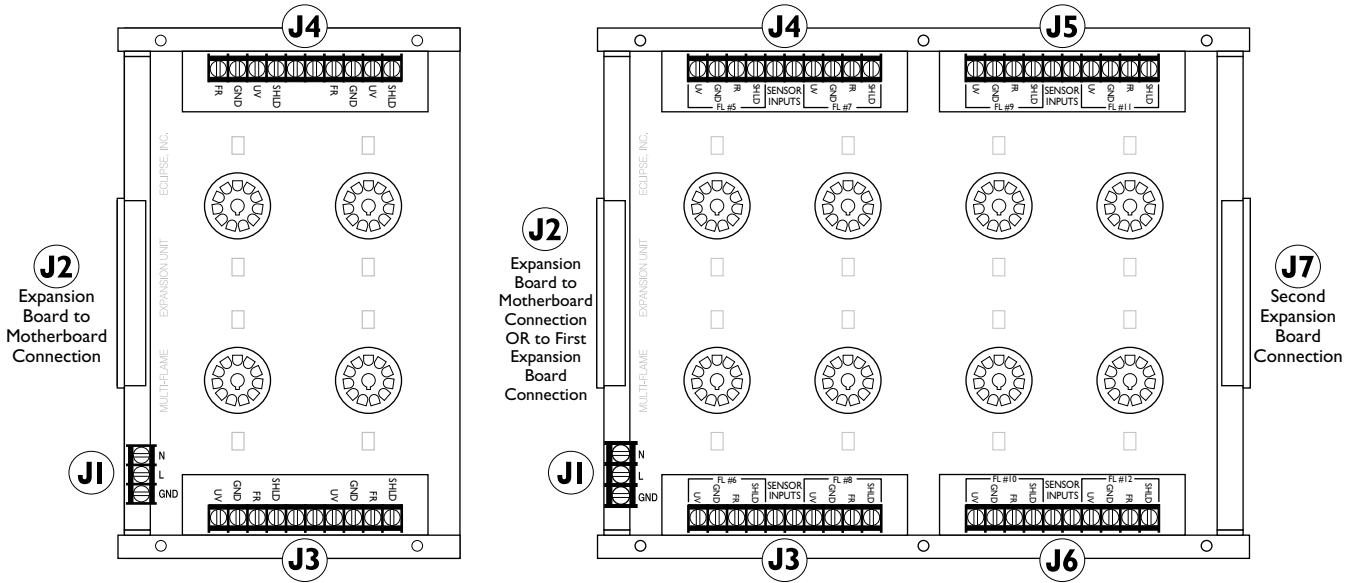
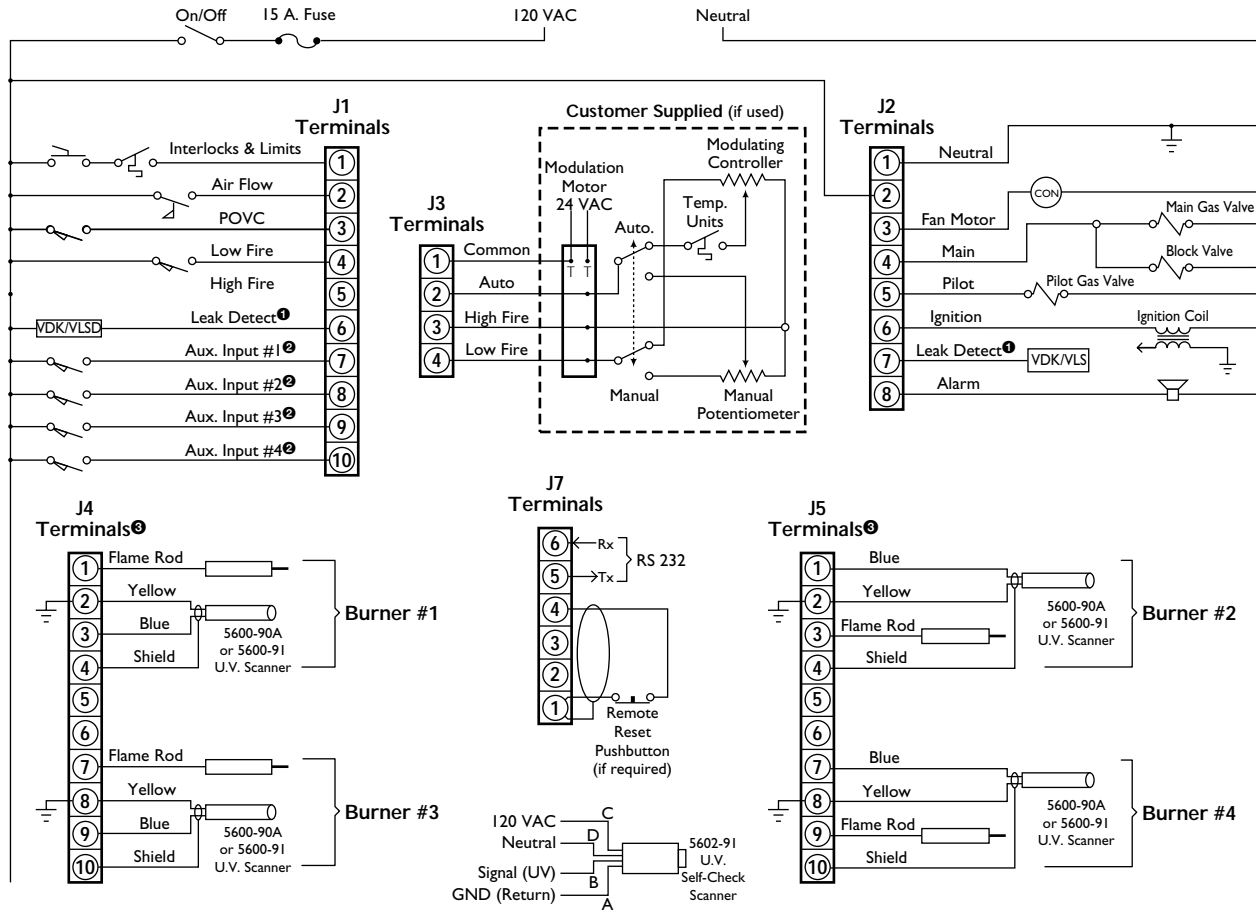

Figure 6.2 Wiring Diagram & Connections–Main Chassis



- ❶ Optional feature.
- ❷ Optional feature which, when not used, must be tied into 120 VAC.
- ❸ Using both sensors isn't mandatory; you may use a flame rod, or a UV scanner, or both.

J1 (Input) Terminals

- 1 – Limits Input
- 2 – Air Switch Input
- 3 – POVC Switch Input
- 4 – Low Fire Switch Input
- 5 – High Fire Switch Input
- 6 – VDK/VLS Input❶
- 7 – Aux. #1❷
- 8 – Aux. #2❷
- 9 – Aux. #3❷
- 10 – Aux. #4❷

Auxiliary Inputs

J2 (Output) Terminals

- 1 – Neutral
- 2 – 120 VAC
- 3 – Fan
- 4 – Main Gas Valve
- 5 – Pilot Gas Valve
- 6 – Ignition Transformer
- 7 – VDK/VLS❶
- 8 – Alarm

Outputs

J3 (Modulation) Terminals

- 1 – Common
- 2 – Auto
- 3 – Hi Fire
- 4 – Low Fire

Modulation Motor Connections for High Fire & Low Fire Start

J4 (Sensors/Burners 1 & 3) Terminals❸

- 1 – Flame Rod
- 2 – Ground (Yellow)
- 3 – U.V. (Blue)
- 4 – Shield Connection
- 5 – Not Used
- 6 – Not Used
- 7 – Flame Rod
- 8 – Ground (Yellow)
- 9 – U.V. (Blue)
- 10 – Shield Connection

Burner #1

Burner #3

J5 (Sensors/Burners 2 & 4) Terminals❸

- 1 – U.V. (Blue)
- 2 – Ground (Yellow)
- 3 – Flame Rod
- 4 – Shield Connection
- 5 – Not Used
- 6 – Not Used
- 7 – U.V. (Blue)
- 8 – Ground (Yellow)
- 9 – Flame Rod
- 10 – Shield Connection

Burner #2

Burner #4

J7 (Interface) Terminals

- 6 – RS 232/RS 485 Interface
- 5 – RS 232/RS 485 Interface
- 4 – Reset
- 3 – Scan
- 2 – Enter
- 1 – Ground

Figure 6.3 Wiring Diagram & Connections–Expansion Board for up to Four Burners

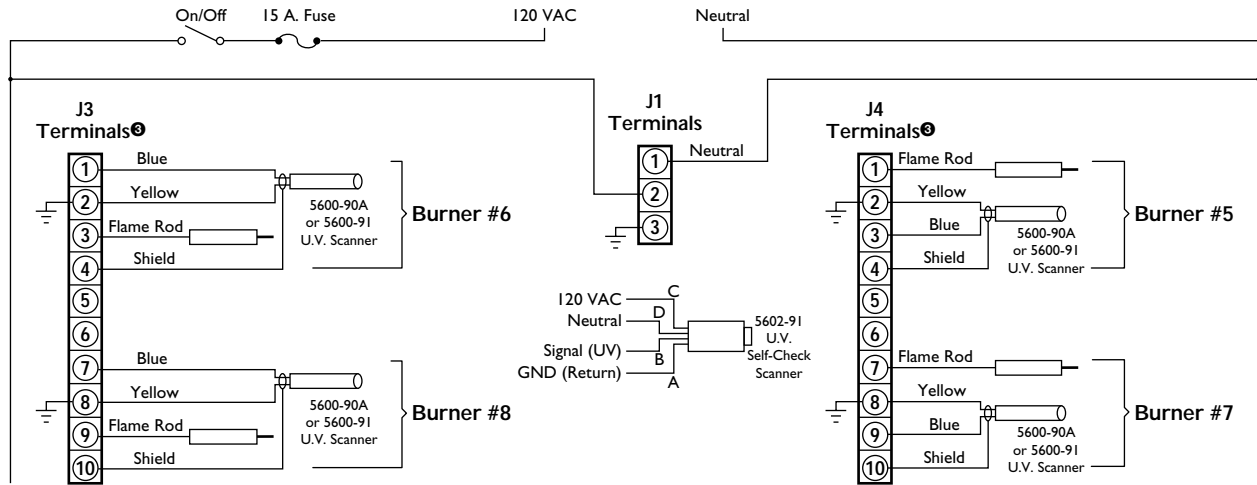

- ❶ Optional feature.
- ❷ Optional feature which, when not used, must be tied into 120 VAC.
- ❸ Using both sensors isn't mandatory; you may use a flame rod, or a UV scanner, or both.

J1 (Input) Terminals

- 1 – Neutral } Expansion Power Inputs
- 2 – 120 VAC
- 3 – Ground

J3 (Sensors/Burners 6 & 8) Terminals❶

- 1 – U.V. (Blue) } Burner #6
- 2 – Ground (Yellow)
- 3 – Flame Rod
- 4 – Shield Connection
- 5 – Not Used
- 6 – Not Used
- 7 – U.V. (Blue) } Burner #8
- 8 – Ground (Yellow)
- 9 – Flame Rod
- 10 – Shield Connection

J4 (Sensors/Burners 5 & 7) Terminals❶

- 1 – Flame Rod } Burner #5
- 2 – Ground (Yellow)
- 3 – U.V. (Blue)
- 4 – Shield Connection
- 5 – Not Used
- 6 – Not Used
- 7 – Flame Rod } Burner #7
- 8 – Ground (Yellow)
- 9 – U.V. (Blue)
- 10 – Shield Connection

Figure 6.4 Wiring Diagram & Connections–Expansion Board for up to Eight Burners

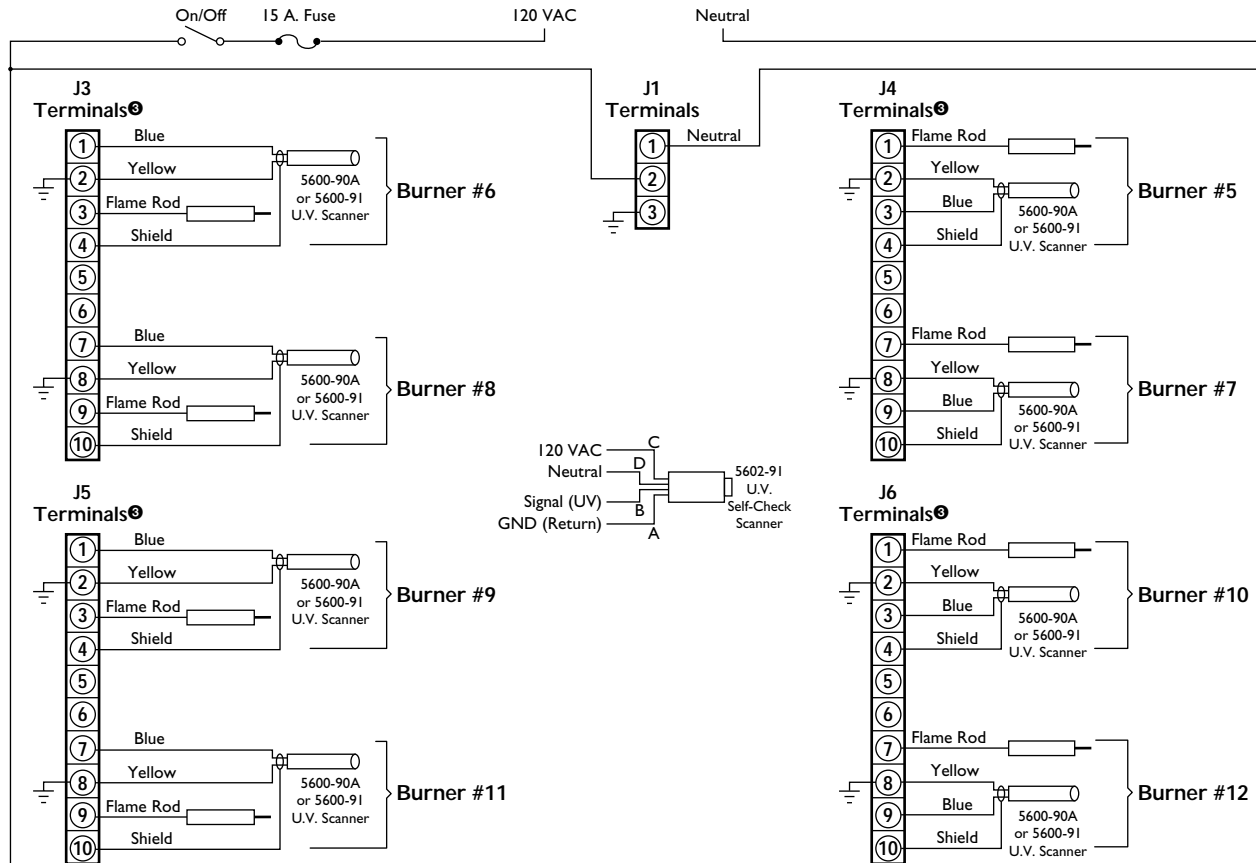

- ① Optional feature.
- ② Optional feature which, when not used, must be tied into 120 VAC.
- ③ Using both sensors isn't mandatory; you may use a flame rod, or a UV scanner, or both.

J1 (Input) Terminals

- 1 – Neutral
 - 2 – 120 VAC
 - 3 – Ground
- Expansion Power Inputs

J3 (Sensors/Burners 6 & 8) Terminals

- 1 – U.V. (Blue)
 - 2 – Ground (Yellow)
 - 3 – Flame Rod
 - 4 – Shield Connection
 - 5 – Not Used
 - 6 – Not Used
 - 7 – U.V. (Blue)
 - 8 – Ground (Yellow)
 - 9 – Flame Rod
 - 10 – Shield Connection
- Burner #6 (terminals 1-4)
Burner #8 (terminals 7-10)

J4 (Sensors/Burners 5 & 7) Terminals

- 1 – Flame Rod
 - 2 – Ground (Yellow)
 - 3 – U.V. (Blue)
 - 4 – Shield Connection
 - 5 – Not Used
 - 6 – Not Used
 - 7 – Flame Rod
 - 8 – Ground (Yellow)
 - 9 – U.V. (Blue)
 - 10 – Shield Connection
- Burner #5 (terminals 1-4)
Burner #7 (terminals 7-10)

J5 (Sensors/Burners 9 & 11) Terminals

- 1 – U.V. (Blue)
 - 2 – Ground (Yellow)
 - 3 – Flame Rod
 - 4 – Shield Connection
 - 5 – Not Used
 - 6 – Not Used
 - 7 – U.V. (Blue)
 - 8 – Ground (Yellow)
 - 9 – Flame Rod
 - 10 – Shield Connection
- Burner #9 (terminals 1-4)
Burner #11 (terminals 7-10)

J6 (Sensors/Burners 10 & 12) Terminals

- 1 – Flame Rod
 - 2 – Ground (Yellow)
 - 3 – U.V. (Blue)
 - 4 – Shield Connection
 - 5 – Not Used
 - 6 – Not Used
 - 7 – Flame Rod
 - 8 – Ground (Yellow)
 - 9 – U.V. (Blue)
 - 10 – Shield Connection
- Burner #10 (terminals 1-4)
Burner #12 (terminals 7-10)

Sensor Installation

7

INTRODUCTION

This section describes the proper wiring, installation and sighting considerations for all sensors that can be used with a Multi-Flame.



Warning

Incorrect sensor installation may cause the sensor to generate a false flame signal, causing unburned fuel to collect in the combustion chamber. The result can be explosions, injuries and property damage. Be certain that the flame sensor detects only pilot and main flames, not glowing refractory, burner or ignition parts.

SENSOR WIRING

Route sensor wiring a sufficient distance from ignition and other high voltage wiring to avoid electrical interference. Wherever possible, try to terminate the flexible metal shield surrounding the leads within inches of the Multi-Flame terminals. If the shield must be grounded to reduce interference, ground the shield at the control end to the shield terminal. For self-checking UV scanners, ground both braided shields. To achieve the maximum wiring distance, the shield should not be grounded (keep in mind that an ungrounded shield provides less protection against electrical interference).

Do not ground the shield to terminal GND.



Note:

Unshielded sensor wiring must not be run in common with other wires; it must be run in separate conduit. Multiple flame sensor wiring must not be run together in a common conduit or wireway. Use #14 to #18 AWG wire suitable for 90°C (194°F) and 600 volt insulation, and run each pair of leads in its own shielded cable. Multiple shielded cables can be run in a common conduit.

FLAME RODS

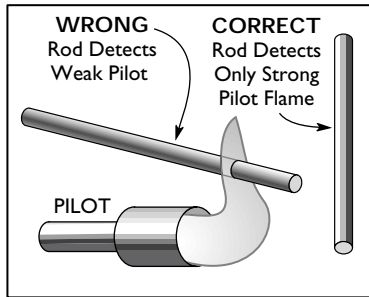
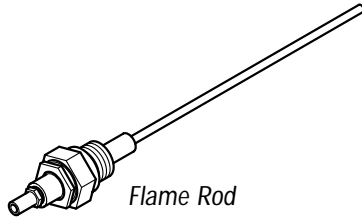

Flame Rod Position

Flame rods should be used only on gas burners. They accumulate soot on oil burners, causing nuisance shutdowns and unsafe operating conditions.

See the burner manufacturer's literature for flame rod mounting location. When installing flame rods, please consider the following:

- 1) Keep the flame rod as short as possible and at least 13 mm (1/2") away from any refractory.
- 2) Position the rod into the side of both the pilot and main flames, preferably at a descending angle to minimize drooping of the flame rod against burner parts, as shown at left. Flame rod position must adequately detect the pilot flame at all burner draft conditions. Extend the rod 13 mm (1/2") into nonluminous flames, such as blue flames from burning an air/gas mixture. For partially luminous flames, such as atmospheric air/gas mixtures, place the rod at the edge of the flame.
- 3) Provide a burner/flame grounding area that is at least four times greater than the flame rod area contacting the flame. The flame rod/burner ground ratio and position of the rod in the flame may need adjustment to yield maximum flame signal strength.
- 4) Ignition interference from the spark plug may increase or decrease the flame signal strength. Reversing the ignition transformer primary leads may reverse this effect. Reducing the spark gap or adding grounding area between the flame rod and spark plug may eliminate the interference.

SCANNERS

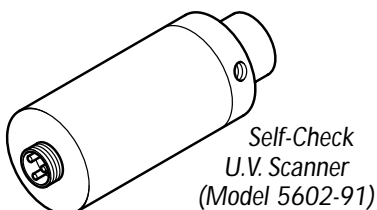
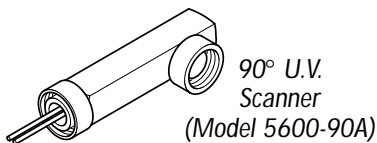
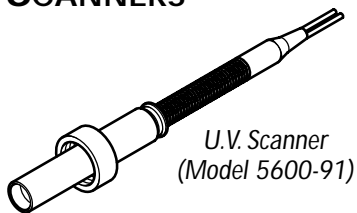

Use only Eclipse scanner models 5600-90A, 5600-91 & 5602-91. Consult the burner manufacturer's instructions for mounting location. When installing scanners, please consider the following:

- 1) Position the scanner within 457 mm (18") of the flame.
- 2) Bushing threads are 1/2 inch F.N.P.T. for scanner models 5600-90A and 5600-91; model 5602-91 has 1 inch F.N.P.T. bushing threads.
- 3) The ambient temperature limits of each scanner varies; check the literature supplied with the scanner. For higher temperatures, use Eclipse heat insulator #15099. If necessary, also use a purge tee.
- 4) An optional magnifying lens (Eclipse #15076) may also be used to increase the flame signal strength in difficult sighting situations.

SCANNER SIGHTING CONDITIONS

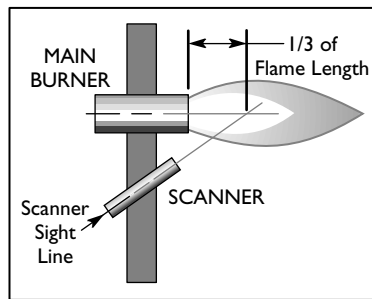

U.V. Scanner Sighting

Aim scanners at the third of the flame closest to the burner nozzle, as shown at left. This is especially true for oil flames which typically have less UV radiation in the outer flame. The scanner should view the intersection of the pilot and main flames. When sighting scanners, please consider the following:

- 1) Sight the scanner away from the ignition spark. Sighting the spark or its reflections from burner internals can cause nuisance shut-downs during burner ignition. If necessary, use a scanner orifice to reduce spark pickup.
- 2) Do not allow the scanner to detect a pilot flame that is too small to ignite the main burner.
- 3) Perform a minimum pilot test when installing or adjusting any pilot or main burner system; see "Minimum Pilot Test" on page 8-1.

Test Procedures

8

INTRODUCTION

This section describes the test procedures that must be performed after installation to insure that the Multi-Flame is operating properly; these procedures are mandatory.

FLAME SIGNAL STRENGTH

Insert the positive probe of a 0-15VDC, one megohm/volt meter into the test point on the Peek-A-Flame, as shown in the photo at left. Connect the negative probe to ground. A good flame signal strength will read between 6 and 11 VDC; anything below 4VDC is inadequate.

MINIMUM PILOT TEST



Voltmeter hook-up to a Peek-A-Flame

Run the following test procedures to ensure that the sensor will not detect a pilot flame too small to reliably light the main flame:

- 1) Manually shut off the fuel supply to the burner, but not to the pilot.
- 2) Start the system normally.
- 3) To enter the pilot test mode, press the RESET and ENTER buttons simultaneously. Then release the RESET button but keep the ENTER button depressed for another 10 seconds. The Limits LED will blink, signalling that the system is in the pilot test mode.
- 4) The control will hold the operating sequence at the pilot flame step. Measure signal strength as described above.
- 5) Reduce pilot fuel until the flame relay drops out. Increase pilot fuel until the flame signal is greater than 4VDC, and flame relay just manages to pull in. This is the minimum pilot. If you don't think this flame will be able to safely light the main burner, realign the sensor so that it requires a larger pilot flame and repeat steps 2 through 5.
- 6) Push the RESET button to exit the test mode and begin the normal start-up sequence again.
- 7) When the sequence reaches the main flame trial for ignition, smoothly restore the fuel supply to the burner. If the main burner does not light within five seconds, immediately shut off the burner supply to shut down the system. Realign the sensor so that it requires a larger pilot flame. Repeat steps 1 through 6 until the main burner lights off smoothly and reliably.

PILOT FLAME FAILURE TEST

- 1) Manually shut off the fuel supply to one individual pilot and main burner, or all burners if the system has a single fuel supply.
- 2) Place system in pilot test mode (please refer to page 5-1).
- 3) Start the system normally. The controller should lock out*; if it doesn't, then the controller is detecting a false flame signal (see Section 7). Find the problem and correct it before resuming normal operation.
- 4) Repeat steps 1 through 4 until all burners have been tested.

MAIN FLAME FAILURE TEST *(For Interrupted Pilot Systems)*

- 1) Manually shut off the fuel supply to the main burner, or all burners if the system has a single fuel supply, but not to the pilot.
- 2) Start the system normally. This should ignite the pilot and lock out* after pilot interruption. If the system does not lock out, the controller is detecting a false flame signal (see Section 7). Find the problem and correct it before resuming normal operation.
- 3) Repeat steps 1 through 3 until all burners have been tested.

SPARK SIGHTING TEST

- 1) Manually shut off the fuel supply to the pilot and main burner.
- 2) Start the system normally.
- 3) Measure the flame signal as described in "Flame Signal Strength" in this section.
- 4) If a flame signal greater than 4VDC is measured for more than three seconds during the trial for ignition, then the sensor is picking up a signal from the spark plug; see "Sensor Wiring" on page 7-1.

LIMITS AND INTERLOCK TESTS

Periodically check all interlock and limit switches by manually tripping them during burner operation to make sure they cause the system to shut down.



Warning

Never operate a system that is improperly adjusted or has faulty interlocks or limit switches. Always replace faulty equipment with new equipment before resuming operation. Operating a system with defective safety equipment can cause explosions, injuries, and property damage.

* The burner at which a flame fails will be identified by a flashing red "Flame Failure" LED on the corresponding Peek-A-Flame.

Maintenance and Troubleshooting

9

INTRODUCTION

This section is divided into two parts:

- The first part describes the maintenance procedures.
- The second part helps you to identify problems that may occur, and gives advice on how to solve these problems.

MAINTENANCE

Preventative maintenance is the key to a reliable, safe and efficient system. The core of any preventive maintenance program is a list of periodic tasks.

In the paragraphs that follow are suggestions for a monthly list and a yearly list.



Note:

The monthly list and the yearly list are an average interval. If your environment is dirty, then the intervals may be shorter.



Caution:

Turn off power before disconnecting or installing sensors, controls or modules.

Monthly Checklist

1. Inspect flame-sensing devices for good condition and cleanliness. Keep the glass lens of scanners clean with a soft, damp cloth, since small amounts of dust will measurably reduce the flame signal strength. Wash the flame rod electrode and insulator with soap and water, then rinse and dry thoroughly.
2. Test all the alarm systems for proper signals.
3. Check ignition spark electrodes and check proper gap.
4. Test interlock sequence of all safety equipment as described on page 8-2: manually make each interlock fail, noting what related equipment closes or stops as specified by the manufacturer.
Test flame safeguard by manually shutting off gas to the burner.

Yearly Checklist

1. Test (leak test) safety shut-off valves for tightness of closure.
2. Test pressure switch settings by checking switch movements against pressure setting and comparing with actual impulse pressure.
3. Visually check ignition cable and connectors.
4. Make sure that the following components are not damaged or distorted:
 - the burner nozzle
 - the spark plugs
 - the flame sensors
 - the flame tube or combustion block of the burner

TROUBLESHOOTING

PROBLEM	POSSIBLE CAUSE	SOLUTION
Cannot initiate start sequence	• Main valve is not closed.	Check proof-of-valve-closure switch.
	• Air pressure switch has not made contact.	Check air pressure switch adjustment. Check air filter. Check blower rotation. Check outlet pressure from blower.
	• High gas pressure switch has tripped.	Check incoming gas pressure; adjust gas pressure if necessary. Check pressure switch setting and operation.
	• Low gas pressure switch has tripped.	Check incoming gas pressure; adjust gas pressure if necessary. Check pressure switch setting and operation.
	• Malfunction of flame safeguard system such as a shorted-out flame sensor or electrical noise in the sensor line.	Have qualified electrician investigate and rectify.
	• Purge cycle not completed.	Check flame safeguard system, or purge timer.
	• Main power is off.	Make sure power is on to control system.
	• No power to control unit.	Call qualified electrician to investigate.
Scrambled messages on remote display.	• Improper grounding in system.	Check grounding in system.
“UNSAFE AIR SHORT” message appears on display.	• Improperly adjusted air switch. • Air switch either shorted or wired wrong.	Check air switch settings. Check wiring to air switch.
Burner flame fails but no flame failure indication occurs.	• A faulty scanner.	Check scanner as explained in checklists in “Maintenance” portion of this Section.
	• Improperly connected sensor wires.	Check wiring diagram on page 6-3 as well as appropriate sensor information in Section 7.
	• Electrical interference from other current carrying wires.	Check Note information on page 7-1 regarding sensor wiring.

Remote Display Messages

10

INTRODUCTION

This section covers how the optional remote display is used with the Multi-Flame. Either remote display (with or without keypad) provides LCD messages which monitor the status of the Multi-Flame's functions as well as any lockout conditions. This section is divided into two parts or tables:

- The first table describes the start-up and shutdown monitoring sequences of the Multi-Flame and how the progress (or halt) of the sequence can be monitored by the messages on the remote display.
- The second table alphabetically lists and explains the diagnostic messages which can appear on the remote display.



Note:

Some of the messages which may appear with some of the options are not shown; refer to Section 5, Function Summary, for details.

Table 10.1 Multi-Flame Operating Sequence

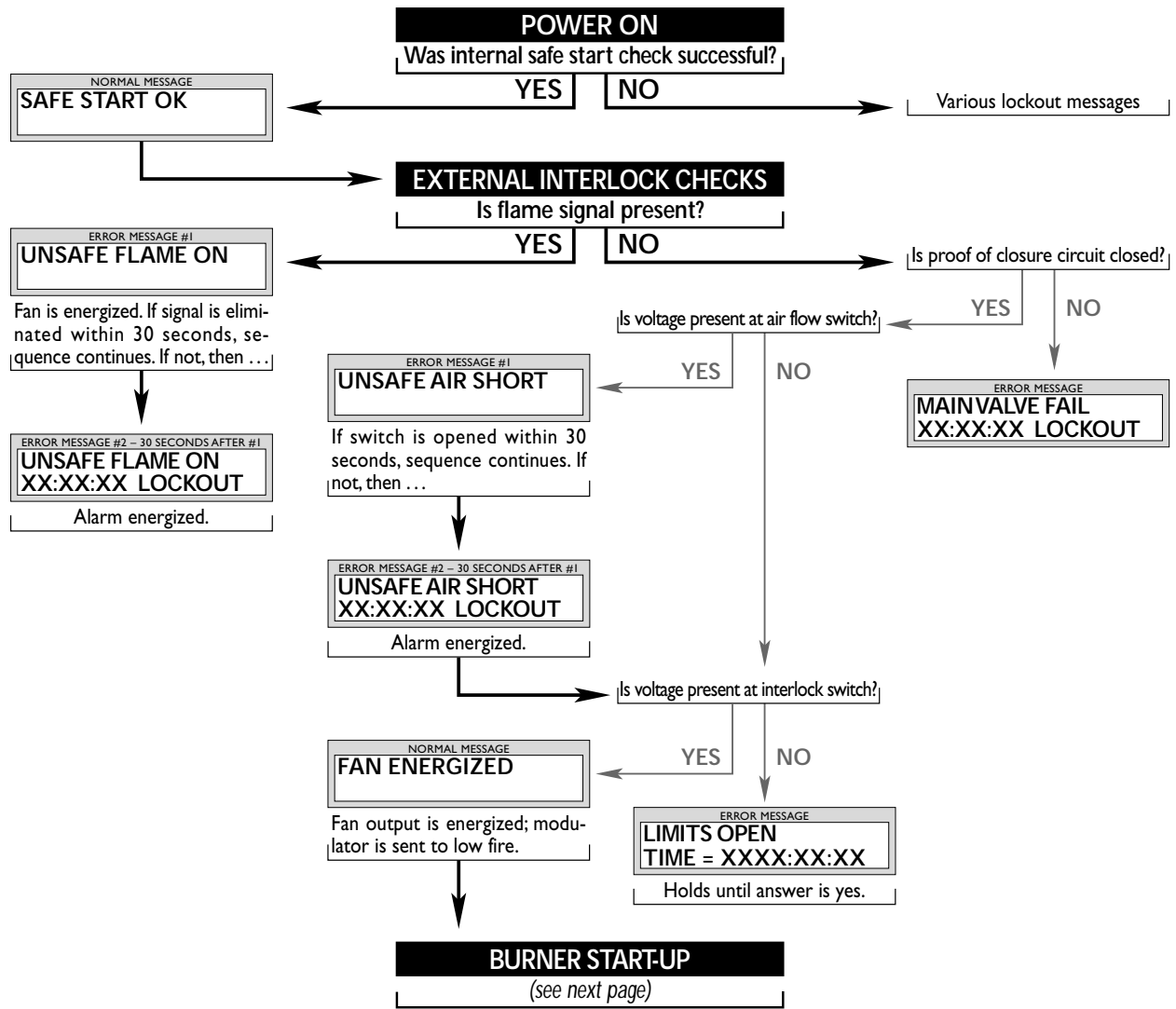

Table 10.1 Multi-Flame Operating Sequence (continued)

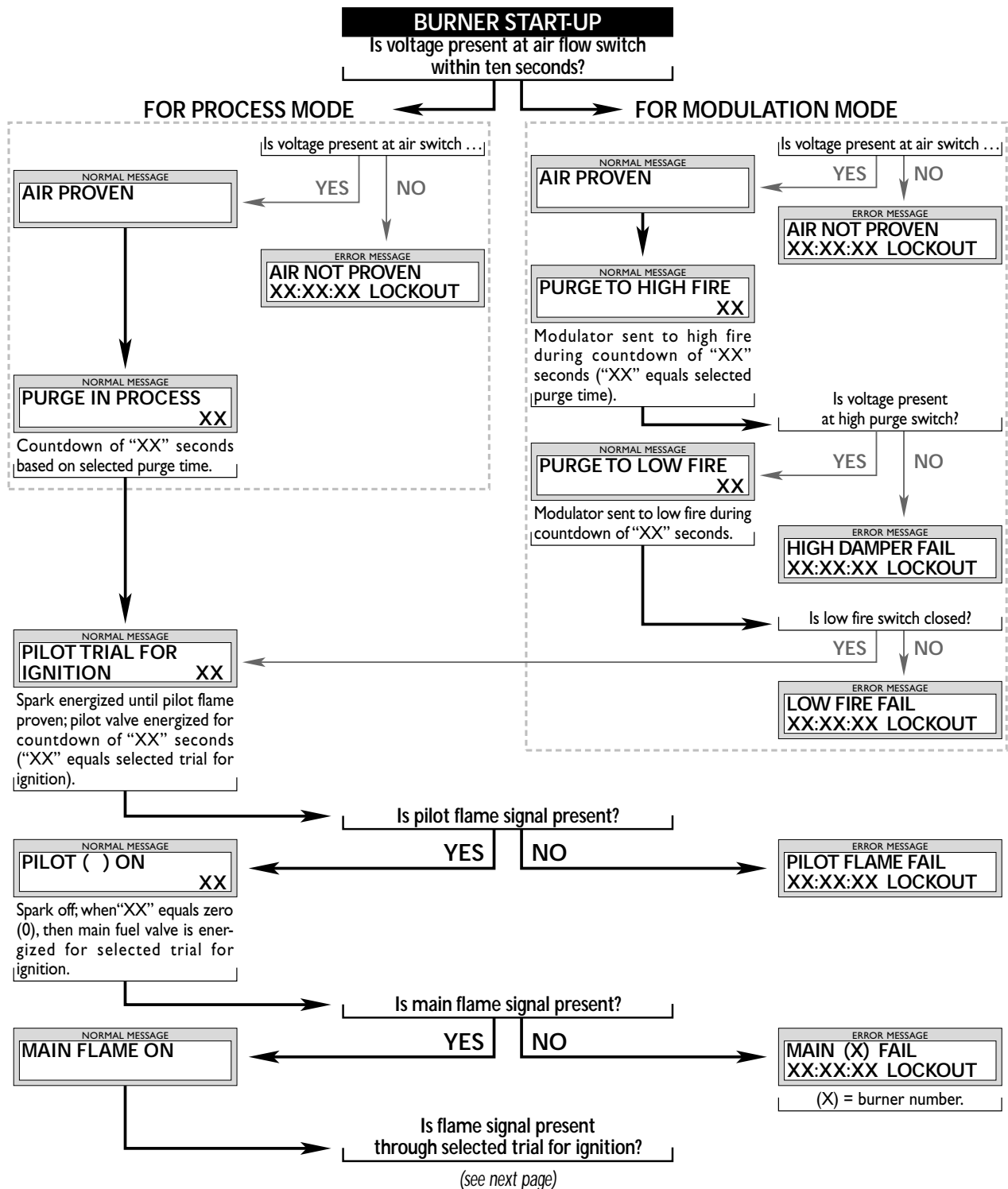

Table 10.1 Multi-Flame Operating Sequence (continued)

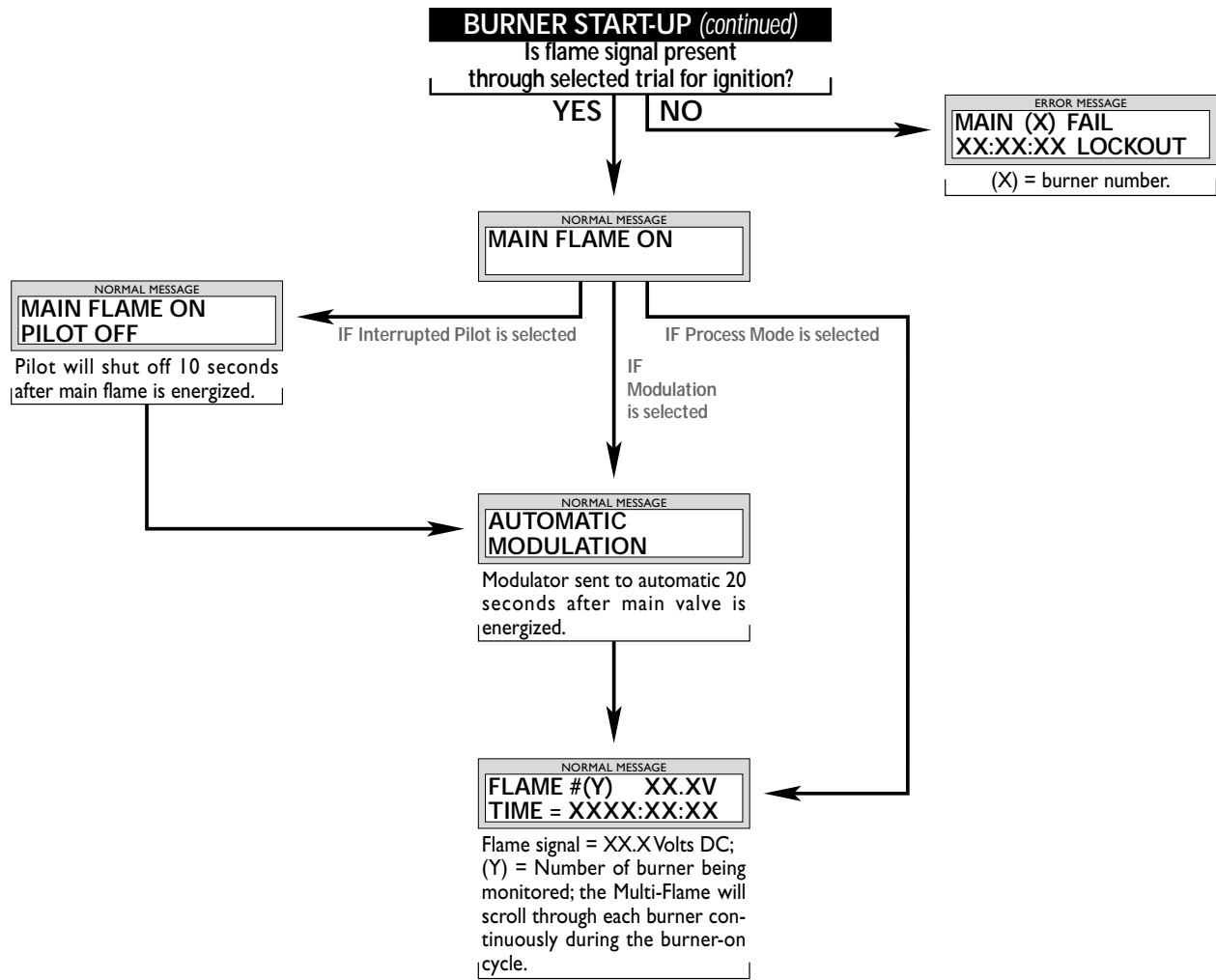

Table 10.1 Multi-Flame Operating Sequence (continued)

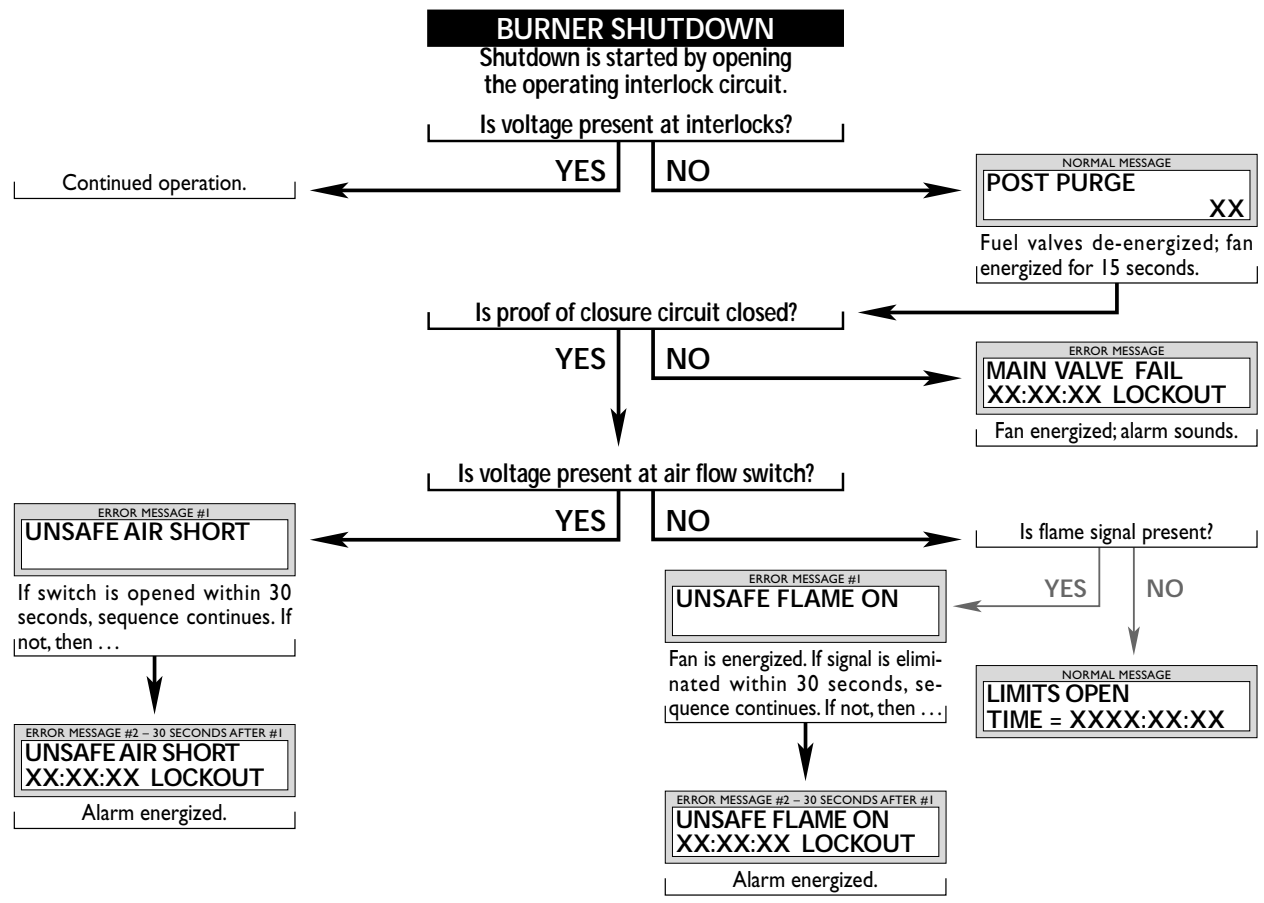

Table 10.2 Remote Display Diagnostic Messages (Listed Alphabetically)

MESSAGE	TYPE	EXPLANATION
AIR FAILURE XX:XX:XX LOCKOUT	Lockout	Combustion air flow limit switch (strip J1, terminal 2) opened for more than two seconds once initially proven.
AIR FAILURE RECYCLING	Status	Combustion air flow limit switch (strip J1, terminal 2) opened; control will recycle one if “recycle” has been selected (see “Interrupted or Intermittent Pilot” in Section 2).
AIR NOT PROVEN XX:XX:XX LOCKOUT	Lockout	Combustion air flow limit switch (strip J1, terminal 2) did not make within ten seconds of fan being energized.
AIR PROVEN	Status	Combustion air flow limit switch (strip J1, terminal 2) closed within ten seconds of fan being energized.
AUTOMATIC MODULATION	Status	Modulating motor is sent to automatic operation. Terminal 1 is connected to terminal 2 on terminal strip J3.
AUX.LIM.#1 FAIL HH:MM:SS LOCKOUT	Lockout	Auxiliary input #1 has lost its voltage during system operation, causing a lockout at the indicated time.
AUX.LIM.#2 FAIL HH:MM:SS LOCKOUT	Lockout	Auxiliary input #2 has lost its voltage during system operation, causing a lockout at the indicated time.
AUX.LIM.#3 FAIL HH:MM:SS LOCKOUT	Lockout	Auxiliary input #3 has lost its voltage during system operation, causing a lockout at the indicated time.
AUX.LIM.#4 FAIL HH:MM:SS LOCKOUT	Lockout	Auxiliary input #4 has lost its voltage during system operation, causing a lockout at the indicated time.
D=INTERNAL FAULT XX:XX:XX:XX LOCKOUT	Lockout	Internal control failure; replace controller.
FAN ENERGIZED	Status	Blower motor (strip J2, terminal 3) is energized at the start of pre-purge.
FLAME ()FAIL RECYCLING	Status	Main flame lost during automatic modulation; control will recycle once if “recycle” has been selected.
FLAME #(X) FAIL XX:XX:XX LOCKOUT	Lockout	Main flame lost during operation in the automatic modulation mode. Burner number (X) given of failed unit.
FLAME (Y) XX.XV TIME=XXXX:XX:XX	Status	Main flame of burner number (Y) is proven in the automatic modulation mode; flame strength is XX.XV (volts DC). Elapsed time is shown in hours:minutes:seconds.
HI DAMPER FAIL XX:XX:XX LOCKOUT	Lockout	High damper or high purge rate switch (terminal “D”) did not make at the end of pre-purge to high fire.
K-INTERNAL FAIL XX:XX:XX LOCKOUT	Lockout	Internal control failure; replace controller.
L-INTERNAL FAIL XX:XX:XX LOCKOUT	Lockout	Internal control failure; replace controller.
LIMITS OPEN TIME=XXXX:XX:XX	Status	The controller has completed its internal checks and is standing by for the interlocks (strip J1, terminal 1) to close.
LOW FIRE FAIL XX:XX:XX LOCKOUT	Lockout	Low fire switch (strip J1, terminal 4) is open just prior to pilot trial for ignition.

Table 10.2 Remote Display Diagnostic Messages (continued)

MESSAGE	TYPE	EXPLANATION
MAIN () FAIL XX:XX:XX LOCKOUT	Lockout	Main flame was not established during the main burner trial for ignition.
MAIN FLAME ON	Lockout	Main valve has been energized and main flame proven during trial for ignition.
MAIN FLAME ON PILOT OFF	Status	Pilot valve (strip J2, terminal 5) is de-energized and main flame is on.
MAIN VALVE FAIL XX:XX:XX LOCKOUT	Lockout	Main valve proof-of-closure is open before startup or after burner shutdown.
NO PURGE SELECT XX:XX:XX LOCKOUT	Lockout	No purge time was selected; lockout prior to purge to high fire.
PILOT FLAME FAIL XX:XX:XX LOCKOUT	Lockout	Pilot flame was not established during the pilot trial for ignition.
PILOT () ON XX	Status	Pilot flame is proven; transformer is de-energized; remaining countdown for pilot trial for ignition is "XX".
PILOT TRIAL FOR IGNITION XX	Status	Pilot valve and ignition transformer are energized; countdown for pilot trial for ignition begins at "XX".
PLT.MVL ENERGIZ. XX:XX:XX LOCKOUT	Lockout	An external source of voltage is present on the ignition, pilot or main output terminals.
POST PURGE XX	Status	15 second post purge is started on burner shutdown; "XX" shows countdown.
PROGM SWITCH ERR XX:XX:XX LOCKOUT	Lockout	DIP switch improperly set or changed during cycle.
PURGE TO HIGH FIRE XX	Status	Modulating motor is sent to high fire; "XX" shows purge countdown.
PURGE TO LOW FIRE XX	Status	Modulating motor is sent to low fire; "XX" shows purge countdown.
RECORD #X	Status	Part of the optional history log, which records the total number of operating cycles and the last lockout messages up to a maximum of 10; see "History Log Activation" on page 5-3 for further details.
RELAY FAIL XX:XX:XX LOCKOUT	Lockout	Internal relay(s) fail initial check. Check ratings. If lockout still occurs after overload is eliminated, replace control.
SAFE START OK	Status	Control has completed internal safe-start check.
UNSAFE AIR SHORT	Status	Combustion air switch is closed before start-up or after shut-down; control holds start-up until switch re-opens; if interlocks close before switch opens, alarm is energized.
UNSAFE AIR SHORT XX:XX:XX LOCKOUT	Lockout	Same conditions as above, except the interlocks close before the switch re-opens, causing a lockout and the alarm being energized.

Table 10.2 Remote Display Diagnostic Messages (continued)

MESSAGE	TYPE	EXPLANATION
UNSAFE FLAME ON	Hold	Flame signal—actual, induced, or runaway scanner—is detected before start-up or after shutdown. The fan is energized. If the cause is corrected within 30 seconds, as in afterburn, the control will turn off the fan and continue the sequence.
UNSAFE FLAME ON XX:XX:XX LOCKOUT	Lockout	Same conditions as above, except the cause has not been corrected within 30 seconds, resulting in a lockout and the alarm being energized.
UNSAFE-FLM-PURGE	Hold	Flame signal—actual, induced, or runaway scanner—is detected during the selected purge time period. The fan is energized. If the cause is corrected within 30 seconds, as in afterburn, the control will turn off the fan and continue the sequence.
UNSAFE-FLM-PURGE XX:XX:XX LOCKOUT	Lockout	Same conditions as above, except the cause has not been corrected within 30 seconds, resulting in a lockout and the alarm being energized.
V-INTERNAL FAULT XX:XX:XX LOCKOUT	Lockout	Internal control failure; replace controller.
VALVE LEAKAGE UNDER TEST XX	Status	Indicates that the optional valve leak sensing device has been activated and the test period (maximum of 35 seconds) has begun.
VALVE LEAK FAIL XX:XX:XX LOCKOUT	Lockout	The test period for valve leak sensing has exceeded 40 seconds and failed; check the gas shut-off valves.
WATCHDOG FAIL XX:XX:XX LOCKOUT	Lockout	Internal control failure; replace controller.
XXXXXXX XXXXXTESTXX	Status	In combination with other messages, shows the control is in the minimum pilot test mode.



Appendix

CONVERSION FACTORS

Metric to English.

FROM	TO	MULTIPLY BY
cubic meter (m ³)	cubic foot (ft ³)	35.31
cubic meter/hour (m ³ /h)	cubic foot/hour (cfh)	35.31
degrees Celsius (°C)	degrees Fahrenheit (°F)	(°C × 1.8) + 32
kilogram (kg)	pound (lb)	2.205
kilowatt (kW)	Btu/hr	3414
meter (m)	foot (ft)	3.28
millibar (mbar)	inches water column ("wc)	0.401
millibar (mbar)	pounds/sq in (psi)	14.5 × 10 ⁻³
millimeter (mm)	inch (in)	3.94 × 10 ⁻²

Metric to Metric.

FROM	TO	MULTIPLY BY
kiloPascals (kPa)	millibar (mbar)	10
meter (m)	millimeter (mm)	1000
millibar (mbar)	kiloPascals (kPa)	0.1
millimeter (mm)	meter (m)	0.001

English to Metric.

FROM	TO	MULTIPLY BY
Btu/hr	kilowatt (kW)	0.293 × 10 ⁻³
cubic foot (ft ³)	cubic meter (m ³)	2.832 × 10 ⁻²
cubic foot/hour (cfh)	cubic meter/hour (m ³ /h)	2.832 × 10 ⁻²
degrees Fahrenheit (°F)	degrees Celsius (°C)	(°F - 32) ÷ 1.8
foot (ft)	meter (m)	0.3048
inches (in)	millimeter (mm)	25.4
inches water column ("wc)	millibar (mbar)	2.49
pound (lb)	kilogram (kg)	0.454
pounds/sq in (psi)	millibar (mbar)	68.95

ILLUSTRATED PARTS LIST

POS. NO.	QTY.	PART NAME	ECLIPSE PART NO.
1	1	Motherboard (6000M)	15431
2	1	Relay module (6000R)	15432
3	1	Logic module (6000L)	15430
4	1	Power module (6000P)	15436
5	1 to 20	Peek-A-Flame (7000)	15427
6	1 to 20	Locking bracket for Peek-A-Flame	15513
7	1	Expansion board (for up to four burners)	15429
8	1 to 2	Expansion board (for up to eight burners)	101112
9	1	152 mm (6 in) cable for expansion board	15734
9	1	914 mm (3 ft) cable for expansion board	15734-1
10	1	183 cm (6 ft) cable for remote display	15426
10	1	305 cm (10 ft) cable for remote display	15426-1
11	1	Remote display without keypad	15420
11	1	Remote display with keypad	15422

To make sure that the downtime of the system is as short as possible in case of a failure, you should keep a stock of spare parts.



Note:

The four burner expansion board **CANNOT** be used in conjunction with the eight burner expansion board.

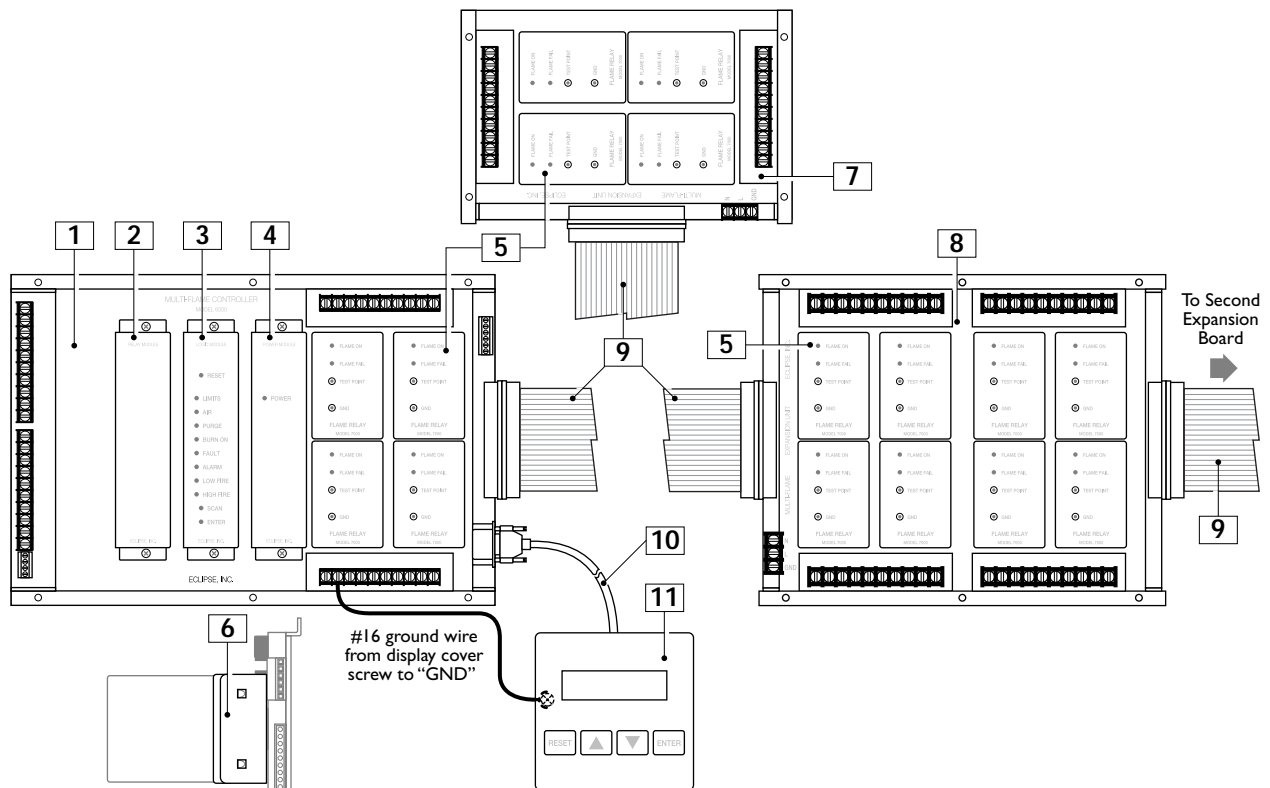



Eclipse Combustion

www.eclipsenet.com